

DRY-RUNNING PISTON COMPRESSOR WITH ELECTRO-HYDROSTATIC DRIVE



clean – reliable – low maintenance

The image shows a modern building facade with a large, three-dimensional 'sera' logo mounted on it. The logo is white with a blue square above the 's'. The building has a mix of grey panels and large glass windows. A bright sun is visible on the left, creating a lens flare effect. The sky is a clear, deep blue.

sera

An enterprise of the future

sera is one of the world's leading companies in the field of dosing and compressor technology – for over 70 years, the **sera** business group has been developing and producing solutions for applications that require precise dosing, feeding and compression of liquids and gases.

As an independent family business with headquarters in Immenhausen and subsidiaries in the UK, South Africa, Spain, Austria and Switzerland as well as over 30 strong partners representing sera in more than 80 countries, we guarantee professional support, advice and services on the ground across the globe.

CLEAN. SAFE. RELIABLE.

We create added value for people and the environment.

sera has an extensive product portfolio, providing the right solutions for many of your applications worldwide. We develop, manufacture and sell high-quality gas compression and feeding products at our facilities, and offer a number of system solutions for a wide range of applications involving hydrogen.

Our customers all over the world also benefit from our comprehensive services, which include assistance with planning and commissioning systems, swift and straightforward global after-sales service, and the development of innovative technologies.



SERVICE

Alongside innovative product and system solutions, providing an exacting and efficient service is also part of who we are. To this end, **sera** offers a wide variety of services ranging from technical support and commissioning through to maintenance and repair.

HIGH VERTICAL INTEGRATION

Quality without compromise comes as standard at **sera**. To guarantee this, we manufacture most of our key components ourselves. High flexibility and a lower risk of losses in expertise, as well as shared production and development experience enable us to excel in delivering durable and high-quality products.

IN-HOUSE DEVELOPMENT

With over 70 years of specialist knowledge and technological expertise, **sera** is known for reliability, flexibility and innovation. We consider it important to have a high degree of innovative strength within the company so that we can impress our customers with the best possible solutions and tailor-made products day after day.

THE RELIABLE SOLUTION FOR CLEAN HIGH-PRESSURE AND EXTREME-PRESSURE COMPRESSION

sera has provided reliable gas compression solutions without oil, contamination or leakage for many decades. Our newly developed, innovative dry-running piston compressors with electrohydrostatic drives perfectly complement our established metal diaphragm technology. They enable reliable and energy-efficient compression of particle-free gases such as hydrogen, nitrogen, helium, argon or ethylene to extreme pressures without the use of lubricants. These innovative piston compressors from sera are ideal when large quantities of gas need to be compressed cost-effectively and safely.

Contamination of the medium with hydraulic fluid from the drive system is eliminated by the vertical format and the design of the compressor units. This makes it possible to safely dispense with complex and expensive sensors for detecting drive fluid.

Thanks to the innovative design and special configuration of the seal and guide systems, the usual lubrication is unnecessary even in high-pressure and extreme-pressure applications.

This compressor technology is made particularly reliable, energy-efficient and low maintenance by its design, construction and drive. A long stroke and low piston speeds mean that it runs quietly and with low wear. When required, the easily accessible seal and guide systems can be replaced in no time without the need for compressor units to be completely dismantled.

ADVANTAGES AT A GLANCE

- OIL-FREE, SAFE COMPRESSION
- ROBUST DESIGN
- HIGH AVAILABILITY
- ENERGY-EFFICIENT DRIVE UNIT
- COMPACT FOOTPRINT
- EASY SERVICING

RANGE OF APPLICATION

- HYDROGEN REFUELLING STATIONS
- POWER-TO-GAS
- TECHNICAL GASES
- AIRBAG INFLATORS
- HOT ISOSTATIC PRESSES
- PRESSURE TESTING TECHNOLOGY

DESIGN AND MECHANICS

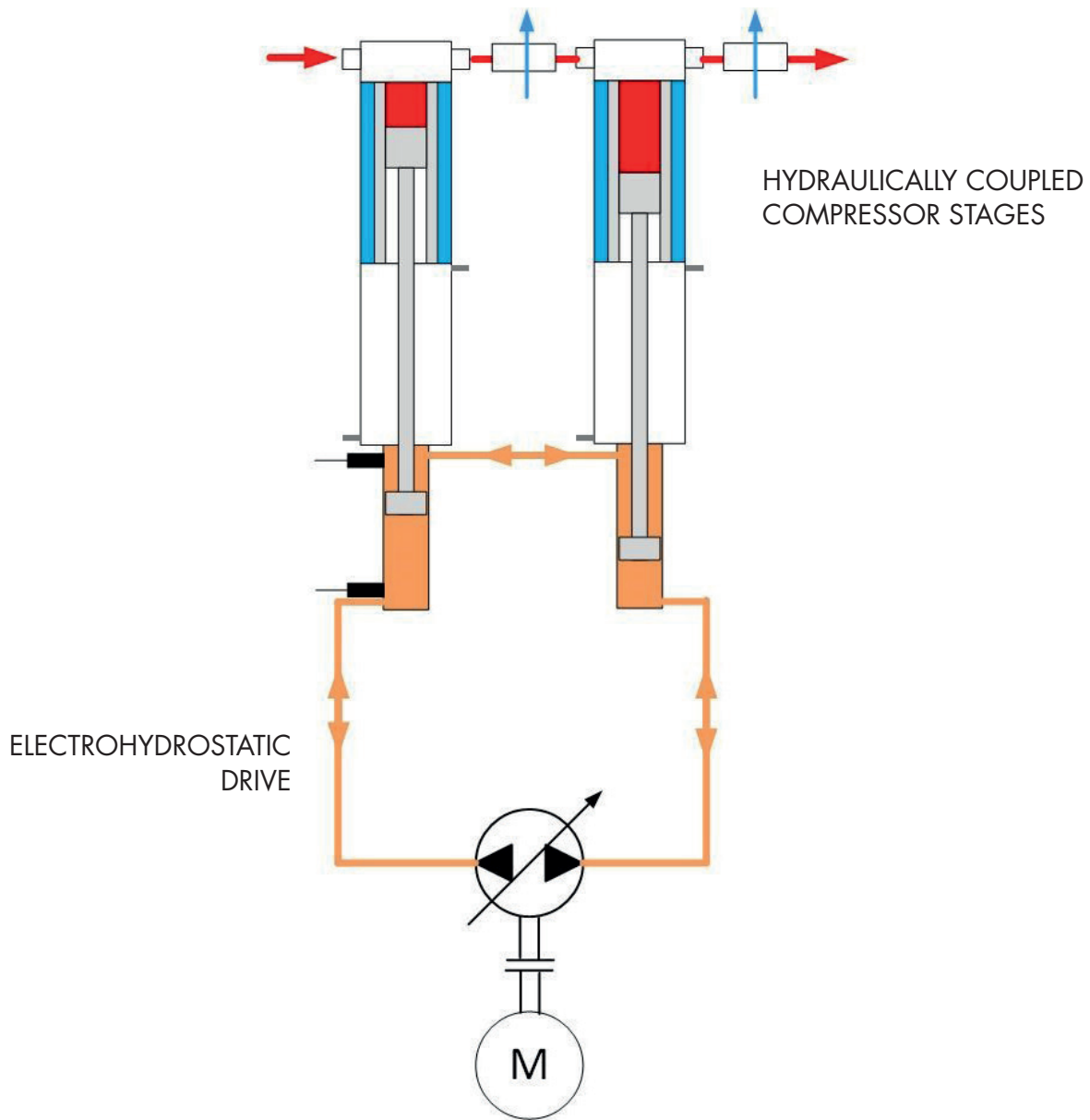

The compressor unit consists of two coaxially arranged vertical gas cylinders, each mechanically connected to and driven by a hydraulic cylinder.

A space between the gas cylinders and drive cylinders safely prevents hydraulic fluid from contaminating the medium. The two drive cylinders are hydraulically coupled with each other via a connecting line.

The gas cylinders are liquid cooled using an outer cooling jacket. This dissipates frictional heat and significantly extends the service life of the seal and guide systems.

The hydraulic cylinders are driven by a hydraulic power unit. Systems with a regulating pump allow infinitely variable control of changes to the number of piston strokes. Changes in stroke direction are controlled by contactless proximity switches.

A particularly advantageous feature is the use of a pivotable axial piston pump which allows the drive cylinder stroke direction to be changed directly by the pump itself. This creates a highly energy-efficient electrohydrostatic drive system. Due to the absence of directional control valves, which are subject to loss, the drive cylinders are pressurised directly by the hydraulic pump oil flow. This creates a robust drive system with integrated overload protection.

MARKETS AND APPLICATIONS



HYDROGEN REFUELLING STATIONS

At a time when fossil fuels are running out and environmental protection is becoming increasingly essential to our planet, hydrogen refuelling stations have found their place in the energy revolution. Vehicles powered by fuel cells require gaseous hydrogen for refuelling. Our innovative compressor is ideal in this application, compressing large quantities of H₂ to up to 1,000 bar. The unique design reliably prevents fuel contamination and satisfies the high cleanliness standards required by vehicle manufacturers.



POWER-TO-GAS

Power-to-gas technology enables excess renewable energy to be converted into other energy carriers such as hydrogen, and then used in other applications. Green hydrogen can be used directly in transportation or, equally, injected into the natural gas grid or H₂ pipelines. Most **sera** power-to-gas compressor stations use our electrohydrostatically powered dry-running piston compressors due to the large quantities of hydrogen that must be reliably and efficiently compressed.



TECHNICAL GASES

Technical gases are used day and night all over the world. They can be found in every sector – be it for welding, cooling, heating or laboratory analysis. These gases are transported using bottles and cylinders of various sizes and pressures which need to be refilled after the gas is removed. Large load fluctuations during filling are characteristic of this application, making the robust design of our electrohydrostatically powered dry-running piston compressors particularly advantageous.

MARKETS AND APPLICATIONS



HOT ISOSTATIC PRESSES

The extreme-strength metal and ceramic components with low dimensional tolerances which are found in the aerospace and automotive industries are often produced using hot isostatic presses. Here, parts are simultaneously hot-pressed and sintered at temperatures of up to 2,000 °C and pressures of 1,000 to 2,000 bar using inert gas. This manufacturing technology generally uses argon, which can be compressed reliably and energy efficiently with our electrohydrostatically powered dry-running piston compressors.



AIRBAG INFLATORS

Airbags have generally become standard equipment for passenger cars in industrialised countries. They have gas generators to provide the gas that activates the airbag. Filling airbag cartridges with a mixture of helium and argon gas demands the highest standards of cleanliness and purity. sera's electrohydrostatically powered dry-running piston compressors are exceptionally suitable for compressing the gas to levels of up to 1,000 bar as safe production is guaranteed by the robust design of these compressors.



PRESSURE TESTING TECHNOLOGY

The automotive and mechanical engineering industries employ a wide variety of test methods – both in testing laboratories and in the course of production operations – to verify the functional properties and impermeability of pressurised components under realistic conditions. Gases used for test purposes include helium, nitrogen, argon CO₂ and hydrogen, and often these must be compressed to extreme pressure levels. Dry-running piston compressors with electrohydrostatic drives are ideal for the many different areas of use.

DESIGN & FEATURES

- 1 Gas valves
- 2 Tie rod
- 3 Gas piston
- 4 Spacer/lantern
- 5 Piston rod
- 6 Drive cylinder
- 7 Sensors
- 8 Electric motor
- 9 Hydraulic pump
- 10 Oil tank
- 11 Cooling jacket



ADVANTAGES IN DETAIL



EASY SERVICING

- Easily accessible maintenance openings
- No need to completely dismantle the compressor to access the seal and guide systems
- Large maintenance openings
- Generous number of maintenance openings in the lantern

OIL-FREE, SAFE COMPRESSION

Oil-free, safe compression and feeding up to 1,000 bar in the standard model thanks to:

- The vertical arrangement of the gas cylinders
- The gas cylinders being above the drive cylinders
- A long spacer between the gas and drive cylinders
- Spacer flushing to remove leaks
- The special gas piston, seal system and guide system design

ROBUST DESIGN

The robust design of the individual components, modules and overall system achieves a high degree of reliability. This effectively prevents failures in the field and errors in production.

HIGH AVAILABILITY

- No lateral forces on the gas pistons due to the absence of a crank drive
- No normal forces due to the dead weight of the gas pistons and piston rods on the guides and seal systems
- No one-sided wear
- Very low piston speeds and quiet operation
- Water-cooled gas cylinders

ENERGY-EFFICIENT DRIVE UNIT

The electrohydrostatic drive is highly energy-efficient. This is achieved through:

- Lower friction loss due to the small number of moving parts
- The lack of valves to interrupt the oil flow
- Large line cross-sections

COMPACT FOOTPRINT

Significantly less floor space is required than with conventional, hydraulically powered compressors. The version featuring a vertical electrohydrostatic drive is particularly compact.

GENERAL TECHNICAL SPECIFICATIONS

SIZE		100
Number of stages		1/2
Max. compression ratio per stage		1:5
Min. suction pressure	bar(g)	1.0
Max. suction pressure	bar(g)	500
Max. discharge pressure	bar(g)	1000
Max. number of double strokes	1/min	20

DIMENSIONS

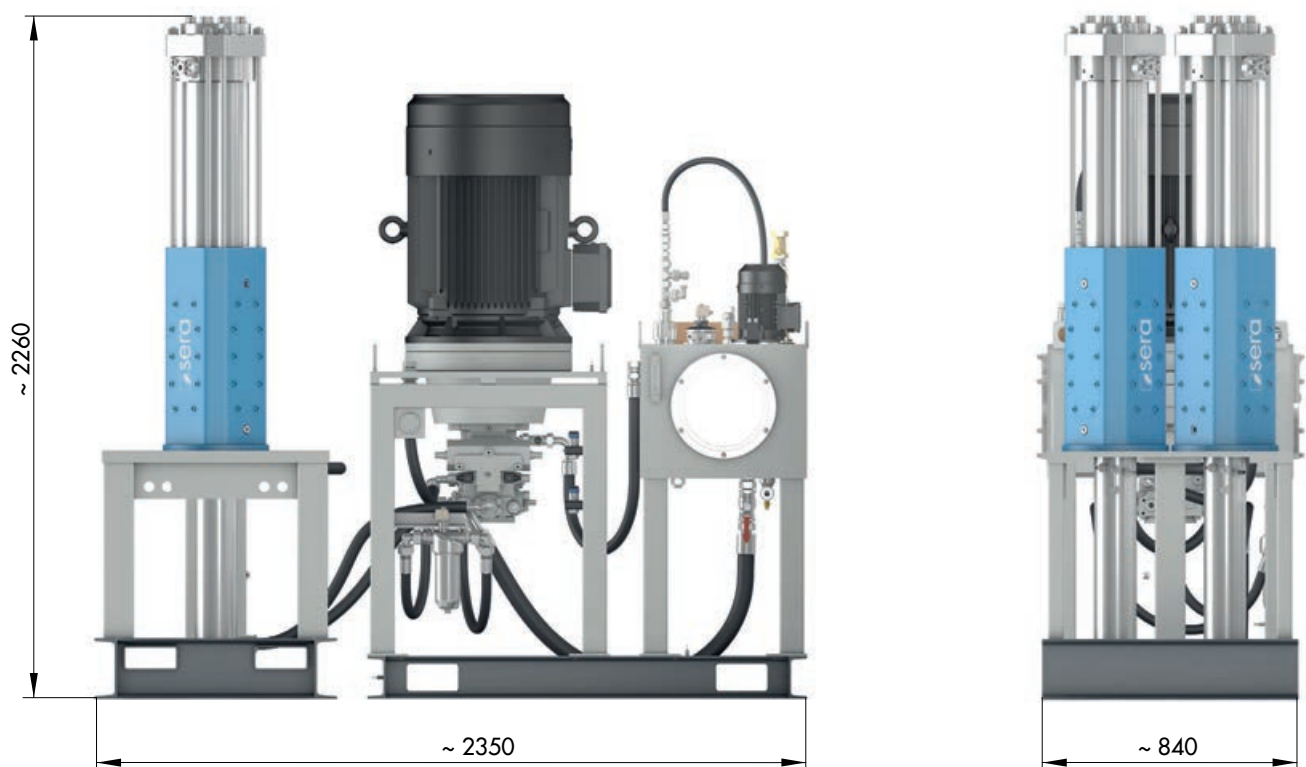

CAPACITY

CAPACITIES WITH HYDROGEN	kg/h	Nm ³ /h
30 bar(g) → 200 bar(g)	17	200
200 bar(g) → 500 bar(g)	50	560
30 bar(g) → 500 bar(g)	15	169
500 bar(g) → 700 bar(g)	57	643
300 bar(g) → 700 bar(g)	36	409
500 bar(g) → 900 bar(g)	52	584
300 bar(g) → 900 bar(g)	41	462

sera dry-running, electrohydrostatically powered piston compressors and systems meet the requirements of the following European Union directives:

- Machinery Directive 2006/42/EU
- Pressure Equipment Directive 2014/68/EU
- ATEX Product Directive 2014/34/EU
- Low Voltage Directive 2014/35/EU

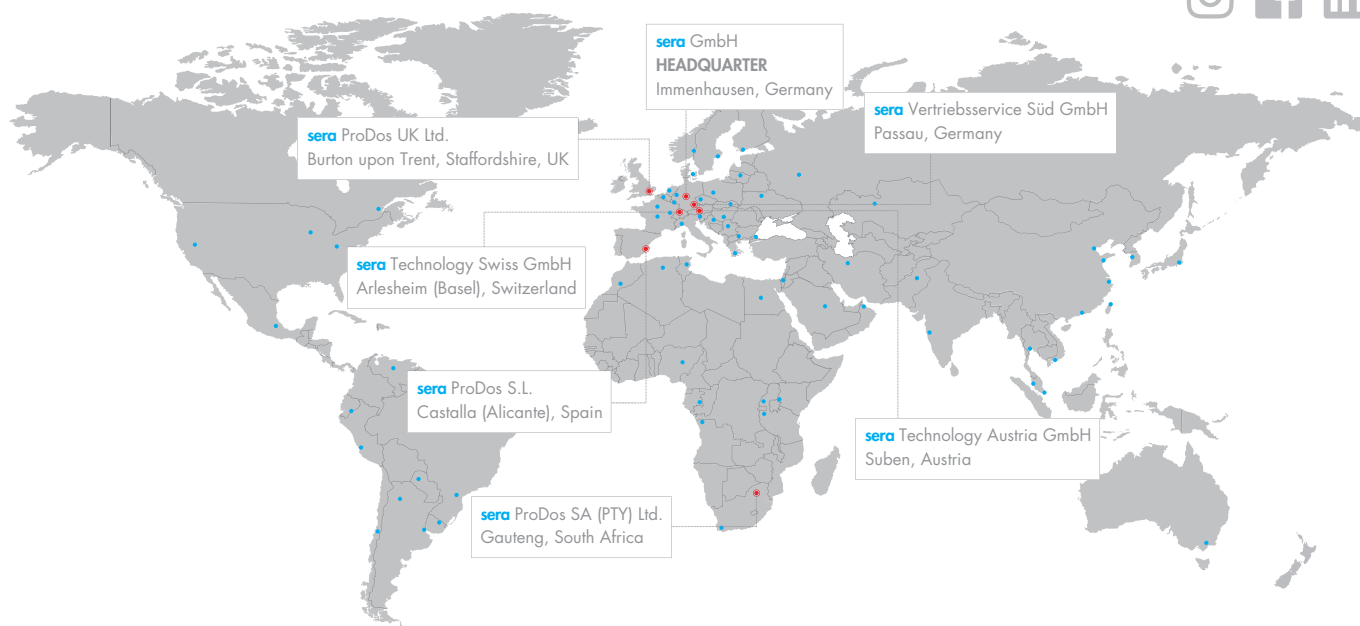

WORKING FOR YOU ALL OVER THE WORLD

sera GmbH

sera-Straße 1
34376 Immenhausen
Germany

Tel.: +49 5673 999-02
Fax: +49 5673 999-03

info@sera-web.com
www.sera-web.com

sera ProDos GmbH

sera-Straße 1
34376 Immenhausen
Germany

Tel.: +49 5673 999-02
Fax: +49 5673 999-03

sales.prodos@sera-web.com
www.sera-web.com

sera Hydrogen GmbH

sera-Straße 1
34376 Immenhausen
Germany

Tel.: +49 5673 999-04
Fax: +49 5673 999-05

sales.hydrogen@sera-web.com
www.sera-web.com

sera Vertriebsservice Süd GmbH

Dr. Ernst-Derra-Straße 8
94036 Passau
Germany

Tel.: +49 851 956099-0
Fax: +49 851 956099-20

sales.sued@sera-web.com
www.sera-web.com

sera Technology Austria GmbH

Eitzelshofen 135
A-4975 Suben
Austria

Tel.: +43 7711 31777-0
Fax: +43 7711 31777-20

sales.at@sera-web.com
www.sera-web.com

sera Technology Swiss GmbH

Altenmatteweg 5
CH-4144 Arlesheim
Switzerland

Tel.: +41 61 51142-60
Fax: +41 61 51142-61

sales.ch@sera-web.com
www.sera-web.com

sera ProDos UK Ltd.

Unit 5, Granary Wharf Business Park
Wetmore Road, Burton upon Trent
Staffordshire DE14 1DU
United Kingdom

Tel.: +44 1283 753400
Fax: +44 1283 753401

sales.uk@sera-web.com
www.sera-web.com

sera ProDos SA (PTY) Ltd.

Unit 3-4, Airborne Park
Cnr Empire & Taljaard Str Bartletts
Boksburg, 1459 Gauteng
South Africa

Tel.: +27 11 397 5120
Fax: +27 11 397 5502

sales.za@sera-web.com
www.sera-web.com

sera ProDos S.L.

Calle Cocentaina n°8,
03420 Castalla
(Alicante)
Spain

Mob: +34 610 418898

sales.es@sera-web.com
www.sera-web.com

www.sera-web.com

 **sera**
EXCELLENCE IN FLUID TECHNOLOGY