

FM Range

Compact Progressing Cavity Pumps

Compact and versatile, the FM Range brings you all the advantages of progressing cavity pumps, in a small, compact and economical design.

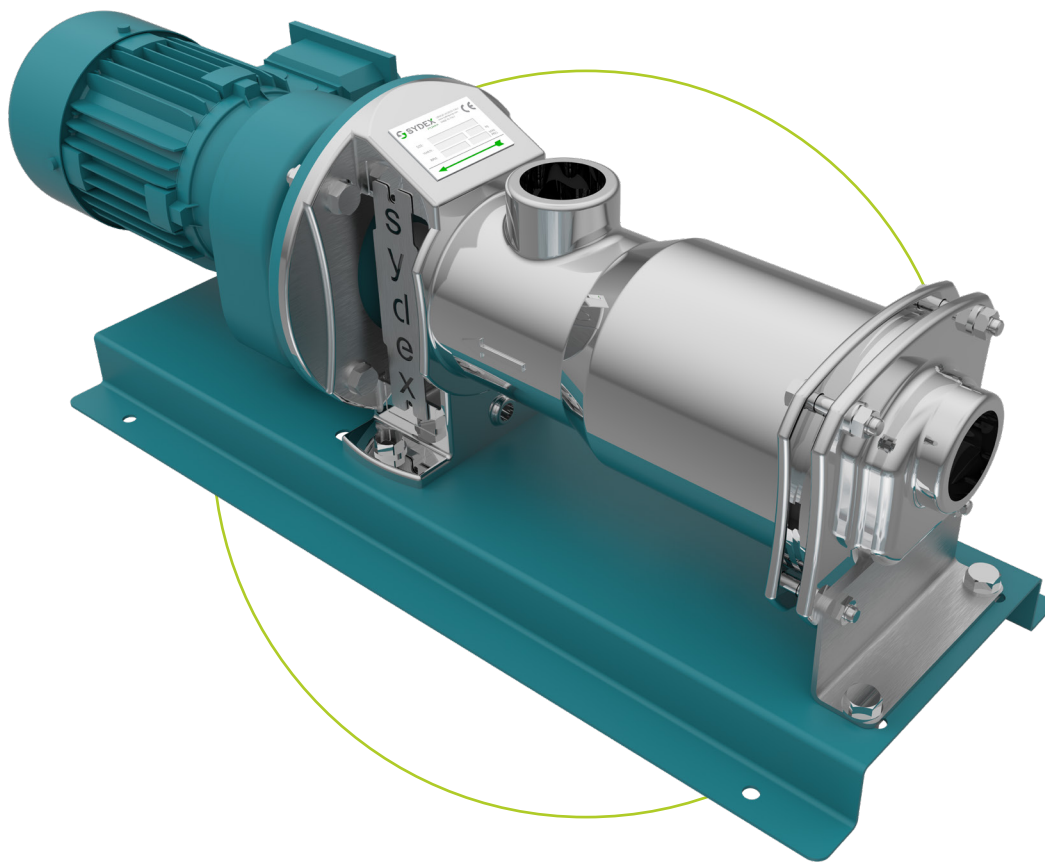

Advantages

- Low noise emissions.
- Low cost of ownership.
- Non-pulsating reliable flow.
- High performance combined with efficient design.
- Different material combinations available to suit applications.
- Extremely simple maintenance.
- Self priming, ideal for suction lifts.
- Wide range of flows 20 up to 10.000 l/h.

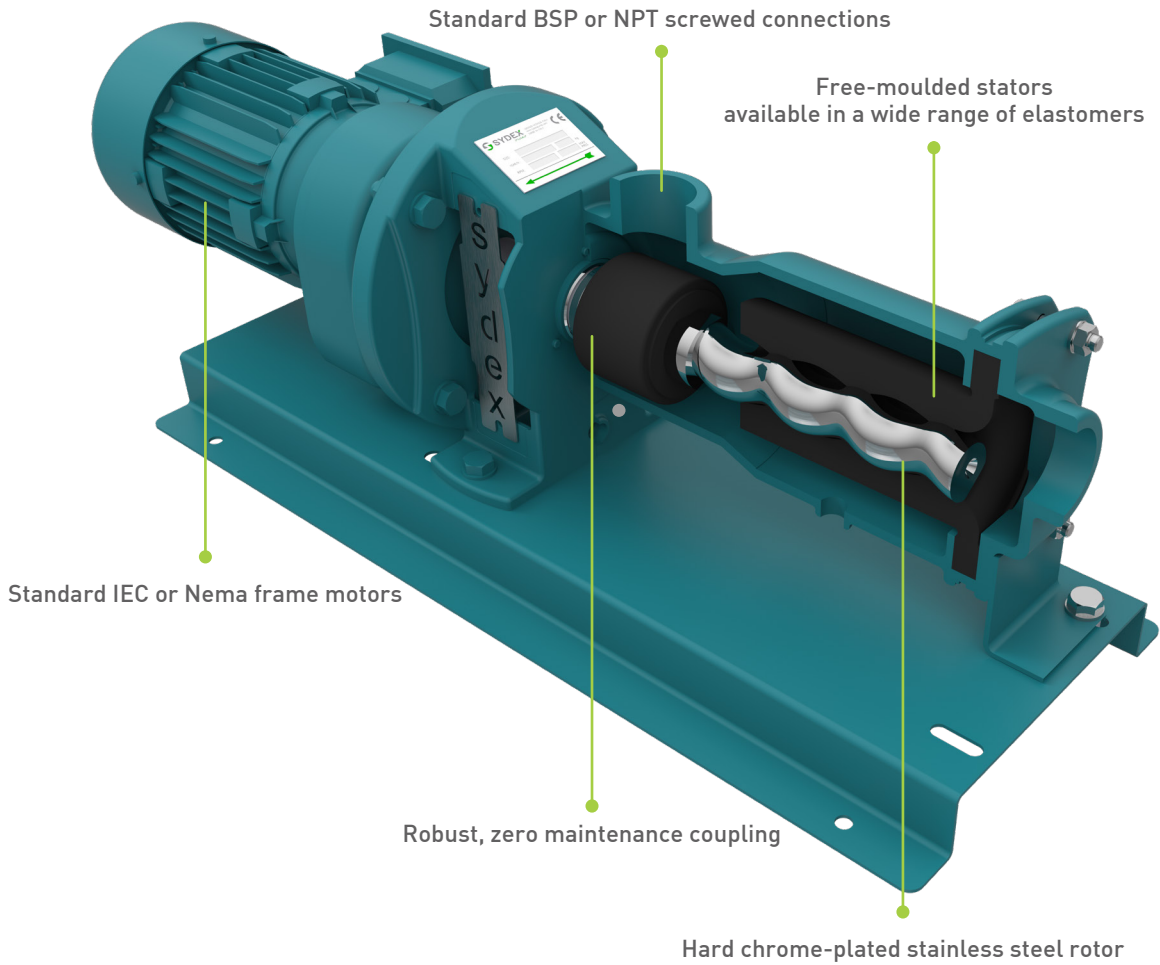

Configurations

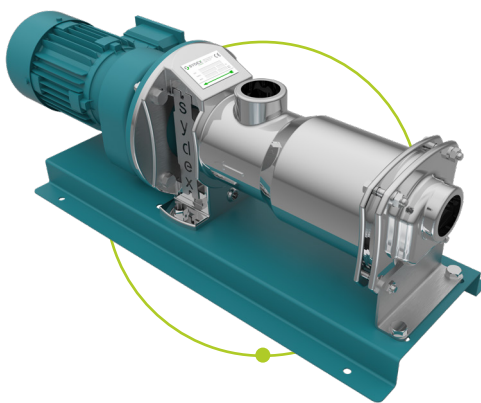

Stainless steel

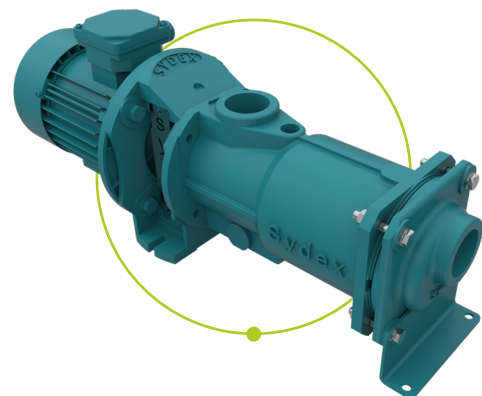

Cast-iron

Application fields

Drainage applications, sampling duties and solids handling.
 Dosing Polymer, bilge pump on board.
 Ideal for OEM pump applications.