

USE AND MAINTENANCE MANUAL

DEFENDER



SYDEX
PUMP



SUMMARY

1	Data	5
1.1	How to read and use the instruction manual	5
1.1.1	Importance of the manual	5
1.1.2	Storing the manual.....	5
1.1.3	Viewing the manual	6
1.1.4	Instruction Manual Update Methodology	6
1.1.5	Recipients	6
1.1.6	Symbology used	8
2	General information	10
2.1	Manufacturer's identification data	10
2.2	Identification data and nameplate of the Defender.....	10
2.3	Statements	11
2.4	Technical Support Information.....	13
3	Safety	14
3.1	General Safety Warnings	14
3.2	Controls and verifications	16
3.3	Contraindications for use	17
3.4	Hazardous Areas	17
3.4.1	Defender Inner Knife Shaft – Side Combs – Cage.....	17
3.4.2	Electrical panel.....	18
3.5	Safety Devices	18
3.5.1	Inspection cover.....	19
3.5.2	Emergency stop on the control panel	19
3.6	Safety instructions intended for machinery operators	20
4	Installation	21
4.1	Transport and movement.....	21
4.2	Storage	21
4.3	Predisposition.....	22
4.4	Placement.....	23
4.5	Electrical connection	24
4.6	Pre-checks	25
4.7	Vacuum tests	25
5	Operation Description.....	26
5.1	Working principle	26
5.2	Main Components	26

5.3	Dimensions	27
5.4	Environmental conditions.....	27
5.5	Vibration	27
5.6	Noise emissions	27
5.7	Standard scope of delivery.....	27
5.8	Electromagnetic environment	28
6	Using the machine	29
6.1	Control panel	29
6.2	Commissioning.....	29
6.3	Modes of Operation.....	29
6.4	Manual mode.....	30
6.5	Auto Mode	30
6.6	Working Parameters.....	30
6.7	Normal Shutdown.....	31
6.8	Restoration.....	31
6.9	Decommissioning.....	31
7	Maintenance	32
7.1	Maintenance status	32
7.2	Machine insulation	32
7.3	Special precautions.....	32
7.4	Cleanliness.....	33
7.5	Lubrication	33
7.6	Routine Maintenance	34
7.7	Scheduled maintenance	35
7.8	Extraordinary Maintenance.....	35
7.8.1	Motor-Gearbox-Coupling	36
7.8.2	Side knife	37
7.8.3	Cage vs Knife.....	38
7.8.4	Rotary knife and mechanical seals	39
7.9	Diagnostics and troubleshooting.....	46
8	Spare parts accessories	47
8.1	Assistance.....	47
8.2	Spare parts.....	47
8.3	Spare parts request form	48
8.4	Recommended Replacement Parts.....	49

9	Additional Instructions	50
9.1	Waste disposal	50
9.2	Decommissioning and disposal.....	50
9.3	Safe working procedures.....	50
10	Attachments	51
10.1	Machine footprint drawings.....	51
10.1.1	Def190/DIN2501DN100PN16/HF482-90I.....	51
10.1.2	Def190/DIN2501DN100PN16/HF482-100J.....	52
10.1.3	Def190/DIN2501DN200PN16/HF682-112L.....	53
10.2	Exploded view machine drawing	54
10.3	Oil data sheet.....	55
10.4	Electrical panel maintenance user manual	56

1 Data

1.1 How to read and use the instruction manual

1.1.1 Importance of the manual

This instruction manual is your guide to the installation, use, maintenance of the Defender you have purchased.

We advise you to scrupulously follow all the advice contained therein, as the proper functioning and durability of the Defender depend on the correct use and methodical application of the maintenance instructions below.

It is good to remember that, in the event of difficulties or inconveniences, Sydex s.r.l. is at your complete disposal for any clarification or intervention.

The instruction manual is an integral part of the Defender.

The instructions, drawings and documentation contained in this manual are of a confidential technical nature, strictly the property of the manufacturer and cannot be reported in any way, either in full or in part.

1.1.2 Storing the manual

The instruction manual must be kept carefully and must accompany the machine in all the changes of ownership that it may have in its life.

Storage should be favored by handling it with care, with clean hands and not depositing it on dirty surfaces.

Parts must not be removed, torn or arbitrarily modified.

The manual should be stored in an environment protected from moisture and heat and in the near vicinity of the machine to which it refers.

1.1.3 Viewing the manual

This instruction manual consists of:

- COVER WITH MACHINE IDENTIFICATION
- INDEX
- INSTRUCTIONS AND/OR NOTES ON THE DEFENDER

By consulting the Cover you can find the Defender model covered in the manual and the serial number of the Defender in your possession.

By consulting the index, it is possible to go back to the chapter and paragraph on which all the notes relating to a given topic are reported.

All instructions and/or product notes are intended to identify safety warnings and procedures for proper operation of the Defender.

1.1.4 Instruction Manual Update Methodology

The manufacturer reserves the right to modify the design and make improvements to the machine without notifying the customers, and without updating the manual already delivered to the user.

1.1.5 Recipients

The manual in question is intended for: the installer, the operator and qualified personnel qualified to maintain the machine.

The personnel responsible for the assembly, use and maintenance of our models must have the necessary skills to perform these tasks. In the event that the aforementioned personnel do not have the necessary technical skills, it will be essential to provide for their adequate training and qualification.

The Defender is intended for industrial use, and therefore professional and not generalized, so its use can be entrusted to qualified figures, in particular who:

- Have reached the age of majority;
- Are physically and mentally fit to carry out work of particular technical difficulty;
- Have been properly instructed in the use and maintenance of the machine;
- They have been judged by the employer to carry out the task entrusted to them;
- Are able to understand and interpret the operator's manual and safety requirements;
- They know the emergency procedures and their implementation;

- Possess the ability to operate the specific type of equipment;
- Are familiar with the specific rules of the case;
- We have understood the operating procedures defined by the machine manufacturer.

1.1.6 Symbology used

The symbols reproduced below are used throughout this publication to draw the operator's attention to the behaviour to be adopted in each operating situation.



Tornio T2 lavorazione rotori
per pompe volumetriche

15 A8 T2

PREMESSE

0













0.0

14/8
6

SAFETY PICTOGRAMS

- PICTOGRAMS IN A TRIANGLE INDICATE DANGER
- PICTOGRAMS CONTAINED IN A CIRCLE IMPOSE A PROHIBITION/OBLIGATION.

Non-exhaustive sample table

P.	Designation
	Dangerous electrical voltage
	Crushing of the upper limbs
	Entanglement
	Dragging
	General danger
	No unauthorised persons
	Do not remove safety devices
	No manual cleaning, oiling, greasing or repair of moving parts
	No work before the voltage has been removed
	No use of water on live or potentially live parts
	Protective gloves required
	Compulsory safety footwear
	Protective helmet mandatory

Tab. 0-6.3

Warnings! Indicates a potentially hazardous situation which, if ignored, may result in personal injury and damage to the machine.

Notes! Underline an essential piece of information.

2 General information

2.1 Manufacturer's identification data

Constructor:

SYDEX SRL

Via Lord Baden Powell,24 – 36045 Lonigo (VI) – Italy

Tel.:+39 0444 43 25 88

Fax:+ 39 0444 43 25 89

Website: www.sydexpump.com

Tax Code and Part. VAT 03075420244/REA No.VI 296900

2.2 Identification data and nameplate of the Defender

Each machine is identified by a CE plate on which the reference data of the same are indelibly reported.

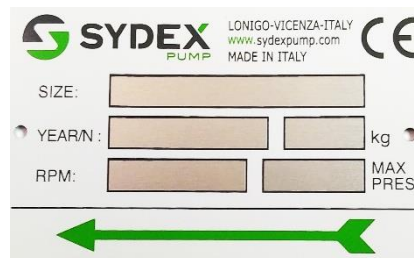

The position of the plate on the machine may vary from machine to machine, it is generally positioned as shown in the figure below.

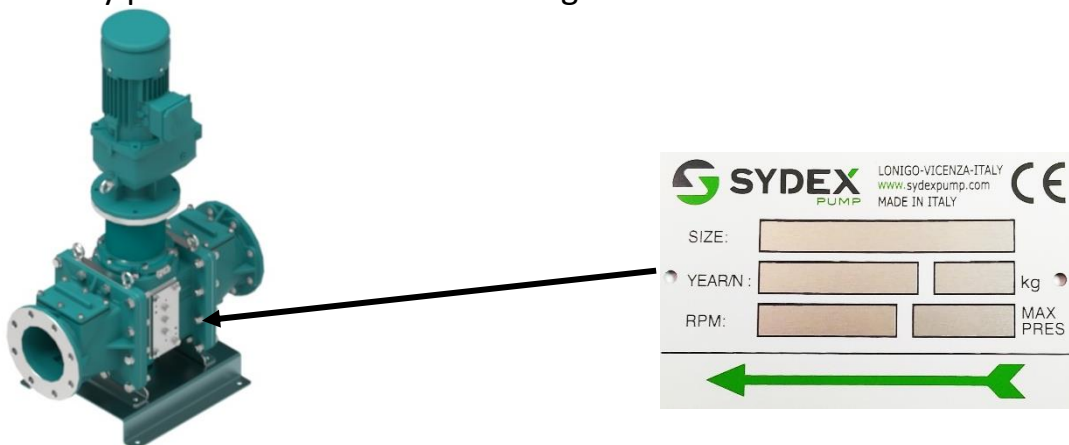

2.3 Statements

The machine is manufactured in compliance with the relevant Community Directives applicable at the time of its placing on the market.



EC DECLARATION OF CONFORMITY

(Annex IIB DIR.2006/42/EC)

In accordance with the requirements of the Machinery Directive 2006/42/EC, SYDEX declares that:

The Machine : Defender

Type :

Code :

Freshman :

Producer : SYDEX SRL

Via Lord Baden Powell, 24

36045 Lonigo (VI) – ITALY

Tel.:+39 0444 432588 – Fax: +39 0444 432589

The aforementioned machinery has been designed and manufactured in accordance with the following European Standards.

ISO 12100-1

Machinery safety – basic concepts, general design principles

ISO 12100-2

Machinery safety – basic concepts, general design principles

BS EN294-1192

Safety distances in order to prevent reaching dangerous areas with the upper limbs

BS EN 809:1998

Pumps and pumping units for liquids – common safety requirements

As an authorised representative of the manufacturer established within the EEC (Directive 2004/108/EC and Low Voltage Directive 2006/95/EC), we declare under our sole responsibility that the equipment complies with the provisions of the above-mentioned directives.



Mec. Ing Luis Piccoli Franco Gechele

Resp. Technical Managing Director



2.4 Technical Support Information

The machines are covered by warranty, as provided for in the general conditions of sale. If, during the period of validity, defective or faulty parts of the machine occur, which fall within the cases indicated in the warranty, the Manufacturer, after the appropriate checks on the machine, will repair or replace the defective parts.

It should be noted that modifications carried out by the user, without the explicit written authorisation of the manufacturer, void the warranty and relieve the manufacturer of any liability for damage caused by a defective product.

Sydex reserves the right to void the warranty in the event that:

- The use of the machinery is different from that agreed in the offer phase;
- The service instructions contained in this manual are not being observed or are not being observed correctly;
- The machinery is modified or transformed without the prior consent of the manufacturer;
- Repairs are carried out by unqualified personnel and/or without the authorization of Sydex's technical department;
- Defenders are fitted with spare parts and accessories that are not original or do not comply with the required technical specifications.

3 Safety

3.1 General Safety Warnings

Note! Before operating the Machine, carefully read the instructions contained in this Manual and carefully follow the instructions contained therein.

The manufacturer has put the utmost effort into designing this machine, as far as possible INTRINSICALLY SAFE.

It has also equipped it with all the protections and safety devices deemed necessary; finally, it has accompanied it with sufficient information to be used safely and correctly.

It is imperative that you diligently follow the following guidelines:

- It is absolutely forbidden to operate the machine automatically with the fixed and/or mobile protectors disassembled;
- It is absolutely forbidden to inhibit the safety devices installed on the machine;
- Operations with reduced safety must be carried out scrupulously respecting the indications provided in the relevant descriptions;
- After an operation with reduced safety devices, the condition of the machine with active guards must be restored as soon as possible;
- Washing operations must be carried out with the electrical and pneumatic separation devices sectioned;
- Do not modify parts of the machine for any reason; In the event of a malfunction, due to a failure to comply with the above, the manufacturer is not liable for the consequences. It is advisable to request any changes directly from the manufacturer;
- Clean machine coverings, panels, and controls with soft and dry or lightly soaked in a mild detergent solution (unless otherwise specified by special needs or specific sanitization protocols); do not use any type of solvent, such as alcohol or petrol, as the surfaces could be damaged;
- Place the machines as established at the time of the order according to the diagrams provided by the manufacturer, otherwise we will not be responsible for any inconveniences.

Warnings! The manufacturer is relieved of any liability for damage caused by the machinery to persons, animals or property in the event of:

- Use of the machine by inadequately trained persons (The technical level of the personnel, in the event of an accident/breakdown, and will decide whether or not the personnel is competent);
- Improper use of the machine;
- Electrical, hydraulic or pneumatic power supply defects;
- Incorrect installation and assembly;
- Deficiencies in the planned maintenance;
- Unauthorized modifications or interventions;
- Use of non-original or non-model-specific spare parts;
- Total or partial non-compliance with the instructions;
- Use contrary to specific national regulations

Due to its construction and application specificities, the Defender could be extremely dangerous, involving serious risks for people, machinery and the environment in the event of non-compliance with safety regulations. Some of the possible consequences are listed below:

- Permanent damage to the Defender and/or the system in which it is installed;
- Damage or malfunction of the Defender;
- **Danger to persons (serious injuries such as amputation of limbs and electric shock)**

3.2 Controls and verifications

Moving parts must be checked as indicated in chapter 6 in this Instruction Manual. If worn or defective parts are not replaced in good time, the manufacturer assumes no liability for damage resulting from accidents.

The checks must be carried out by expert personnel; they must be visual and functional, with the aim of ensuring the safety of the machine.

They include:

- Verification of all load-bearing structures, which must not present any crack, breakage, damage, deformation, corrosion, wear or alteration with respect to the original characteristics;
- Verification of all mechanical parts including lifting chains;
- Verification of all the safety devices installed on the machine;
- Verification of all connections with pins and screws;
- Machine operation check;
- Verification of the machine;
- Verification of the electrical supply circuit.

The results of this verification must be reported on a special sheet.

Notes! If anomalies are detected, they must be eliminated before putting the machine back into operation, and the expert who follows the verification must note the repair on the card, thus giving approval to the use of the machine. If the person carrying out the check finds cracks or dangerous anomalies, he must promptly notify the machine manufacturer. Put the machine out of service if operating anomalies occur by providing for the appropriate and/or repairs.

3.3 Contraindications for use

The machine must not be used:

- For uses other than or not mentioned in this manual;
- In an explosive atmosphere;
- With safety devices excluded or not working;
- With electrical jumpers and/or mechanical means that exclude the user/parts of the machine itself.
- With protective casings not correctly positioned.
- With the power and control cabinets open

3.4 Hazardous Areas

Notes! In order to avoid personnel accidents and permanent damage to the machine, it is imperative that technicians who install, operate and maintain the Defender have read and understood the basic safety instructions contained in this manual.

The areas intended as hazardous of the machine are:

3.4.1 Defender Inner Knife Shaft – Side Combs – Cage

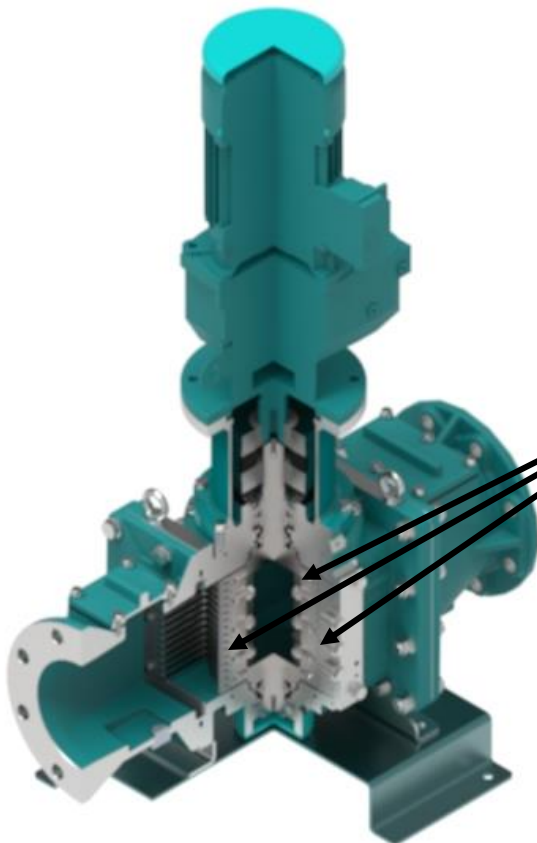

	Entanglement
	Dragging
	General danger
	Cut hazard

3.4.2 Electrical panel



Dangerous electrical voltage

3.5 Safety Devices

The following safety devices are installed in the machine:

- 1- Inspection cover locked with screw tightening.
- 2- Emergency stop on the control panel.

Warnings! It is strictly forbidden to remove the inspection cover while the Defender is running. In case of non-compliance with the safety regulations, it can lead to serious risks for the person, serious injuries such as amputation of limbs.

3.5.1 Inspection cover

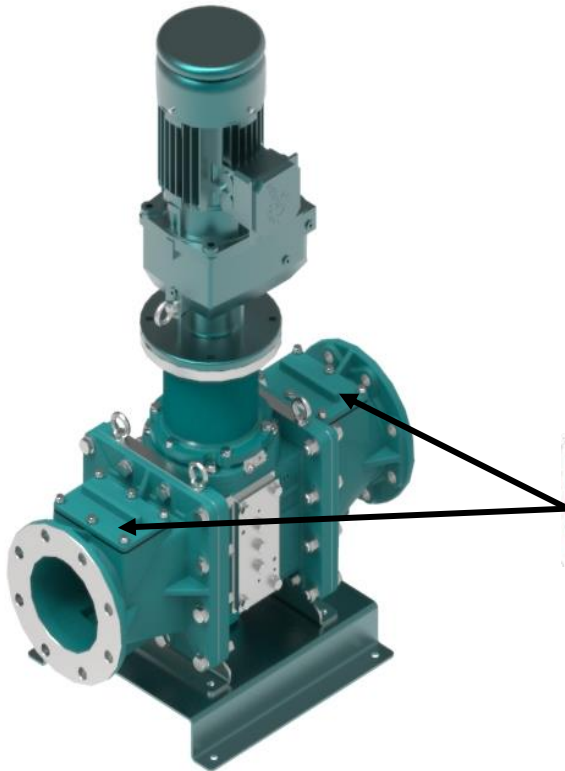

Do not remove safety devices

3.5.2 Emergency stop on the control panel

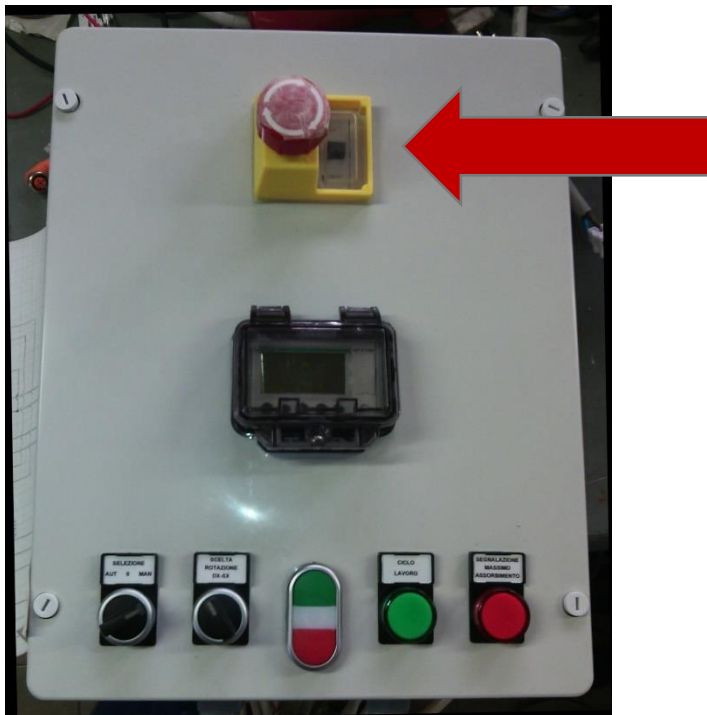

3.6 Safety instructions intended for machinery operators



- Maintain safe distances while the Defender is running
- Do not put your hands or fingers into the unit
- Inspection covers should not be removed while operating the Defender
- Before putting the Defender back into operation, make sure that the guards and covers have been replaced correctly.
- Do not insert metal objects inside the Defender box.



Always wear suitable safety clothing:

- Helmet
- Gloves
- Safety shoes



- Eliminate any risk of exposure to electric current
- Switch off and disconnect the power source before starting installation, repair and maintenance work



- Do not lift heavy machinery above personnel

4 Installation

4.1 Transport and movement

The machine can be transported with a normal vehicle capable of supporting the weight and size of the machine; being supplied fully assembled, it must only be placed in the place of use.

It is preferable to lift the machine with a forklift truck equipped with special forks.

Always check the correct weight balance of the machine when it is transported by forklift in order to prevent unexpected movements or falls to the ground of the machine.

For moving around the plant, the machine can be transported with a bridge crane, providing for it to be harnessed correctly through the use of ropes or bands with adequate resistance characteristics depending on the weight of the machine itself.

Notes! The personnel involved in transporting and storing the Defender must be familiar with the operation of the lifting equipment and the slinging techniques, in accordance with the applicable accident prevention regulations.

Notes! The manufacturer is not liable for damage caused to persons or property by the use of lifting systems other than those described above.

4.2 Storage

In the event of inactivity, the machine must be stored taking the following precautions:

- Store the machine indoors;
- Grease unpainted parts;
- Protect the machine from shocks and stresses;
- Protect the machine from humidity and high temperature fluctuations;
- Do not allow the machine to come into contact with corrosive substances.
- Spray the shaft with anti-rust lubricant and rotate it monthly.

4.3 Predisposition

For installation, it is necessary to prepare a manoeuvring area suitable for the size of the machine and the chosen lifting equipment. The preparation of the machine must be carried out in such a way as to optimise the ergonomics and safety of the workplace: leave a sufficient area around it to allow easy use and handling of the material to be processed and for maintenance and adjustment operations.

Warnings! The purchaser is responsible for determining the spaces required for the installation of the Defender.

The connection to the electrical system that powers and manages the machine must be made by specialized and qualified personnel in compliance with the wiring diagram and the provisions prescribed in the laws and/or technical standards on safety in the workplace and electrical systems in force. Adequate safety devices must be provided for its operation in accordance with the provisions on safety in the workplace.

Notes! The company is not responsible for damage to property, people and/or animals caused by non-compliance with this provision.

In order to achieve an adequate level of safety, the electrical system to which the machine belongs must provide, at the user's complete expense, an earthing system according to the provisions of the user's country, and anything else for a correct execution in a workmanlike manner, according to laws and/or technical standards on the safety of the workplace and electrical systems. Provide connections for grounding the machine housing.

Notes! These predispositions are always the responsibility of the user and nothing can be attributed to the manufacturer for damage to property, people and/or animals due to a bad electrical connection.

4.4 Placement

The machine must be positioned level and/or fixed by screws with respect to the support surface, which must have characteristics such as to support the weight of the machine. Failure to level or not hold the flooring sufficiently can cause anomalies.

The flow direction is indicated by the arrows on the nameplate and on the Defender box.

The Defender should always be mounted with the rotor on the upstream side and the cage on the downstream side. The complete unit can be mounted on the piping line as shipped or in two sections as described below.

- 1- If the Defender's rotor is lubricated with grease, the unit can be mounted in either a horizontal or a vertical plane.
- 2- If, on the other hand, the gearboxes are lubricated with oil, attention must be paid to the correct positioning of the breather must be positioned from the top of the unit. Before mounting the oil-lubricated Defender in a different position than originally intended, contact Sydex.

If the installation takes place on an existing pipe line, the removed part must be compatible with the center distance of the machine. The mounting holes of the mating flanges should be arranged in line with each other and with the mating of the Defender flanges.

Contact Sydex's technical department for details on flange center distance.

In the event that the probability of some residual materials entering the system regularly increases, a horizontal orientation of the pipe line is preferable, thus reducing the probability that the residual material will reach the blades.

It is advisable to install a hatch on the upstream side of the Defender.

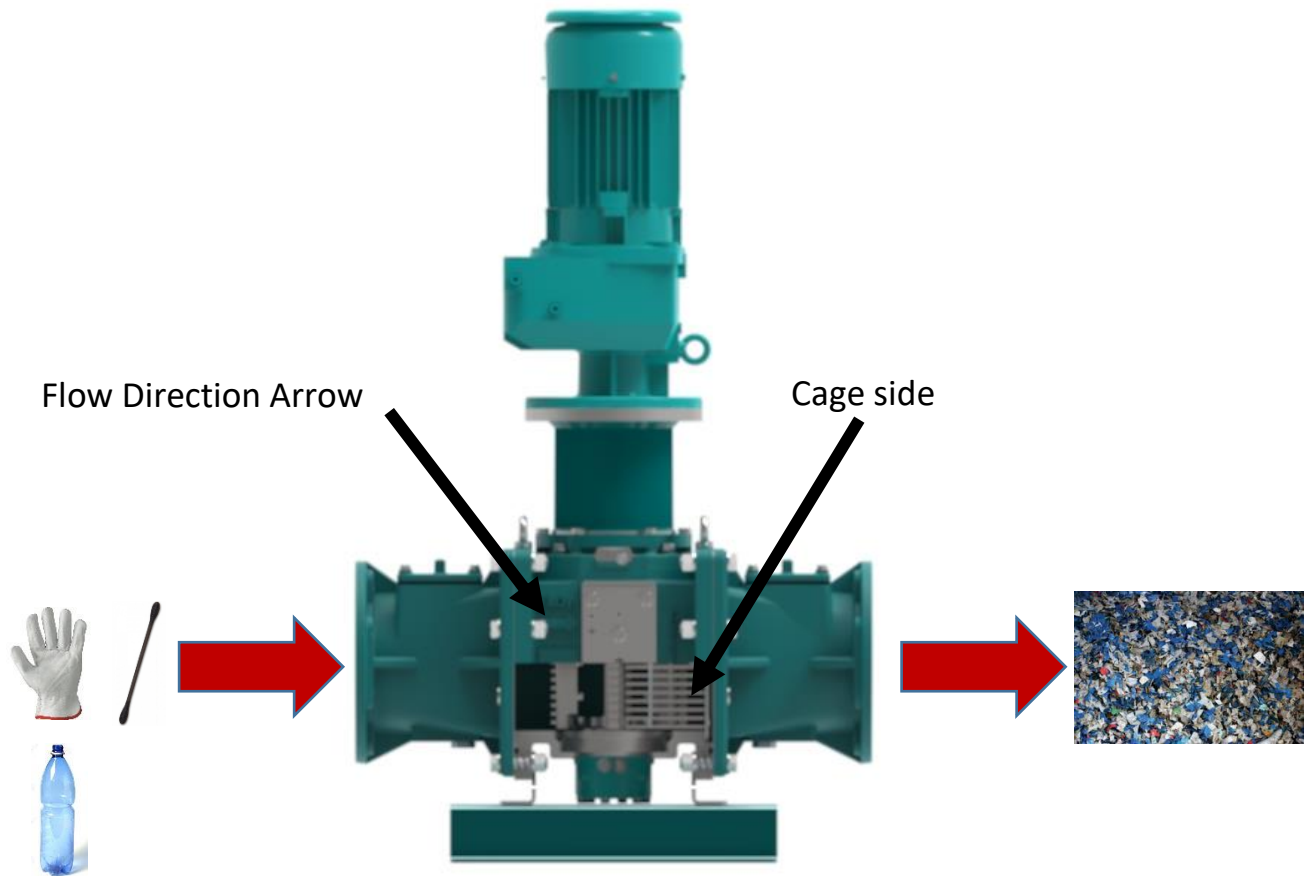

4.5 Electrical connection

The internal connections of the machine are made by qualified persons of the manufacturer. The electrical connection between the machine panel and the customer's electrical distribution supply line must be made by persons qualified by the customer.

The wiring diagram necessary to make a correct connection to the power and control power supply is also included.

Notes! Observe the following guidelines:

- Install a circuit breaker on the main circuit breaker;
- Install a switch as close to the unit as possible;
- Install a residual current circuit breaker.

4.6 Pre-checks

The following steps must be carried out before each machine is put into operation:

- Control of all safety systems;
- Control of protections; Signage control

Before the machine is put into operation, a series of checks and controls must be carried out in order to prevent errors or accidents during the commissioning phase:



- Check that the machine has not been damaged during the assembly phase;
- To check, with particular care, the integrity of electrical panels, control panels, electrical cables and pipes, etc.
- Check the exact connection of all external energy sources;
- Check the lubricant level to prevent damage to the gearbox;
- Check the noise and vibration level. All units are thoroughly tested and checked at the factory before shipment; However, displacement may occur during transportation or installation, so some units may require a short period of adjustment. In the event that a high level of noise and vibration persists, consult Sydex's technical department.
- For oil-lubricated gearboxes: Make sure the vent is positioned at the highest possible point. Check the gearbox manufacturer's manual for more information.

4.7 Vacuum tests

Before carrying out the loading operation, carry out an empty test in order to check for any anomalies.

5 Operation Description

5.1 Working principle

The Defender consists of three main working elements: a rotating cylindrical element open inside to facilitate the passage of the fluid is composed of cutting combs (knife shaft), a fixed counter-knife cage and two side combs. The comb of the knife shaft fits into the slots of the side comb, then into the slots of the cage against the knife, thus shredding large solids and eliminating any residues at each pass: a considerable open space is still maintained to ensure continuous flow inside the unit. The Defender works in both directions of rotation. To avoid blocking the Defender, due to large solids, the PLC intervenes by changing (automatically) the direction of rotation until the solid is shredded. This prevents the unit from blocking and does not overload the electric motor, protecting it from failure.

Note! It is recommended to periodically reverse the direction of rotation to even out wear and extend the life of the machine.

Warnings! To ensure proper operation, the Defender must be supported by a plc controller supplied or approved by Sydex. Failure to install such a device could result in premature damage to the machinery and void the warranty of the machine. It is also essential that the PLC is properly connected to the control panel.

5.2 Main Components

The machine consists of the following main parts:

- Engine
- Gearmotor
- PLC

Notes! For details of the various components, see the technical specifications of the products attached to this manual.

5.3 Dimensions

The size of the Defender depends on the configuration you require. The overall dimensions will be attached to the offer and subsequently to the order.

Notes! For standard configurations, see the overall dimensions attached to this manual.

5.4 Environmental conditions

The machine does not require any special environmental conditions. It must be installed on a solid, level floor. Permitted temperatures from -5° to 50° C, with humidity not exceeding 50% at 40° C or not exceeding 90% at 20° C. Contact the Sydex technical department if the environment has different characteristics listed above.

Warnings! The machine is not suitable for working in an environment with an explosive or corrosive atmosphere or with an excessive presence of dust (Protected Atmosphere).

5.5 Vibration

In conditions of use in accordance with the instructions for correct use, vibrations are not such as to give rise to dangerous situations.

5.6 Noise emissions

The noise level of Sydex models does not exceed 80 dB (A), in line with the indications in the Machinery Directive 2006/42/EC. The level guaranteed by the machine does not include the control unit and the pipes.

5.7 Standard scope of delivery

The machine is supplied complete for commissioning.

It is supplied with:

- Instruction Manual for use and general maintenance;
- Specific manuals of the various components installed;
- Spare parts tables of the individual components;

- General wiring diagram and specific components;
- Operator panel programming manual;

5.8 Electromagnetic environment

The machine is designed to operate correctly in an industrial electromagnetic environment, falling within the emission and immunity limits provided for by the following harmonized standards:

IEC EN 61000-6-2 Electromagnetic Compatibility (EMC)

Generic standards – Immunity for industrial environments

IEC EN 61000-6-4 Electromagnetic Compatibility (EMC)

Generic Standards – Emission for Industrial Environments

6 Using the machine

6.1 Control panel

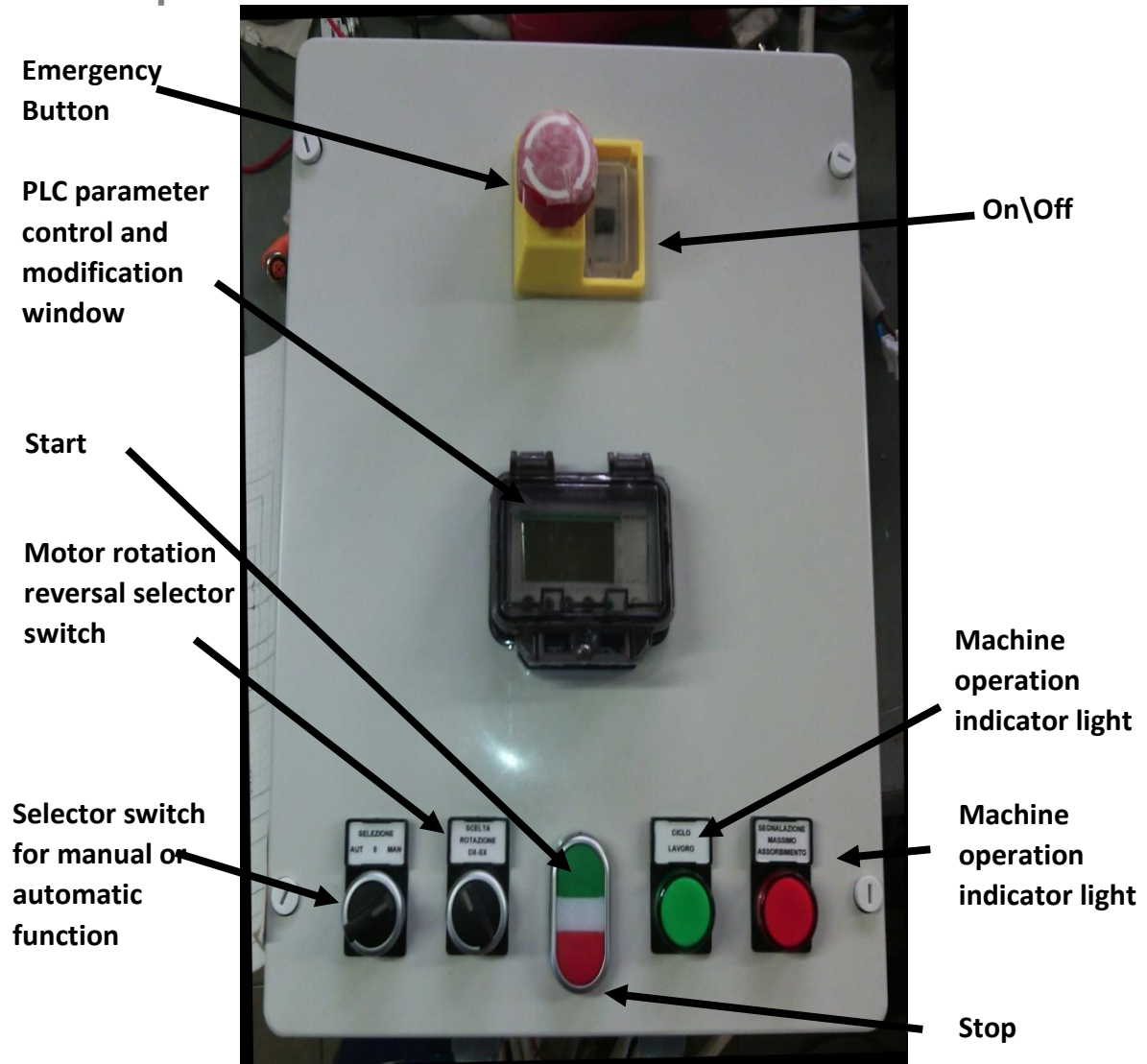

6.2 Commissioning

Power the machine, or the line to which it belongs.

Check that all the machine locks are enabled and fitted. If necessary, restore them.

6.3 Modes of Operation

The operation of the machine is automatic and manual.

6.4 Manual mode

Make sure that the emergency button is not pressed, if so, rotate it, proceed with the reset by turning the emergency button about 30 degrees.

Press the black on/off button of the main switch. Using the function selectors, select the manual cycle and the desired direction of rotation.

Press the start button (green button) to operate the Defender.

Notes! In manual mode, the Defender always rotates in the selected direction until the operator presses the stop button or the emergency button.

6.5 Auto Mode

Make sure that the emergency button is not pressed, if so, rotate it, proceed with the reset by turning the emergency button about 30 degrees.

Press the black on/off button of the main switch. Use the function selector to select the automatic cycle.

Press the start button (green button) to operate the Defender.

Notes! In automatic mode, the Defender rotates in a cyclical manner. The PLC will reverse the direction of travel whenever the motor exceeds the maximum set current. You can stop the cycle whenever you want by pressing the stop button or the emergency button. After 4 continuous reversal cycles, the PLC automatically stops the rotation.

Notes! The red operating light on indicates that the engine has reached maximum absorption and has reversed.

6.6 Working Parameters

To set the working parameters, follow these instructions:

- Set the function selector switch (MAN-0-AUT) to position 0;
- Press button 4 and 6 at the same time to enter the programming menu, the first line will start flashing;
- Select the data row to be changed by pressing buttons 1 or 4;
- To change the data you are interested in, press 2 or 3;
- To save the new value, press button 5.

Notes! The data I can change are:

- Motor tripping threshold current (up to a maximum value of 6A.)
- Rotation exchange cycle number
- Engine pause time for reverse intervention

Warnings! Contact Sydex Technical Before Creating a New PLC Configuration. The company is not responsible for damage to persons and/or animals caused by non-compliance with this provision.



6.7 Normal Shutdown

The machine is stopped by pressing the stop button and setting the function selector to position 0.

6.8 Restoration

After manually resetting the mushroom emergency button by rotating it clockwise by about 30 degrees, the machine can be used normally.

6.9 Decommissioning

During long periods of inactivity, the power supply must be disconnected from the main electrical panel.

7 Maintenance

7.1 Maintenance status

Maintenance operations must be carried out with the machine under the conditions described under "CONDITION OF THE MACHINE" in section 6.6 of scheduled maintenance.

7.2 Machine insulation

Before carrying out any type of maintenance or repair, it is necessary to isolate the machine from the power supply.

Then operate the emergency button by operating it and cutting off the power from the line.

Warnings! The electrical insulation of the parts of the line on which maintenance work is to be carried out must be safe and prove the lack of risk for the workers.

Examples include the LOTO – OSHAS NFPA 70 (The National Electrical Code (NEC), or NFPA 70) procedures

7.3 Special precautions

When carrying out maintenance or repair work, the following recommendations should be applied:

- Before starting the work, display a "MACHINE UNDER MAINTENANCE" sign in a clearly visible position;
- Do not use solvents and flammable materials;
- Be careful not to disperse lubricating liquids into the environment;
- At the end of the work, restore and correctly fix all the guards and guards removed or opened;
- For replacement work on particular parts on the machine, refer to the specific manuals

Warnings! The manufacturer will not be held responsible for non-compliance with the listed recommendations and for any other non-compliant or not mentioned use these indications.

7.4 Cleanliness

It is necessary to provide adequate cleaning of the machine. The frequency of cleaning to be carried out by the user will be defined by the user himself based on the use of the machine.

As a precautionary measure, we recommend a thorough weekly cleaning with non-acidic or aggressive products in compliance with food safety directives.

Notes! It is forbidden to use water on electrical parts such as panels, motors and push-button panels.

7.5 Lubrication

Lubricate/grease the mechanical parts that contribute to the movement of the moving parts of the machine. Periodically check the level of lubricant in the various gearboxes according to the instructions in the specific manuals. Proper lubrication is essential for the operation of the machinery. Time interventions are based on normal operation and must be reviewed by individual users if necessary on the basis of current use and the operating environment. An adequate level of lubrication is important to extend the life and operational efficiency of the machinery.

Notes! A sudden drop in the lubricant level can indicate the failure of rotating mechanical seals.

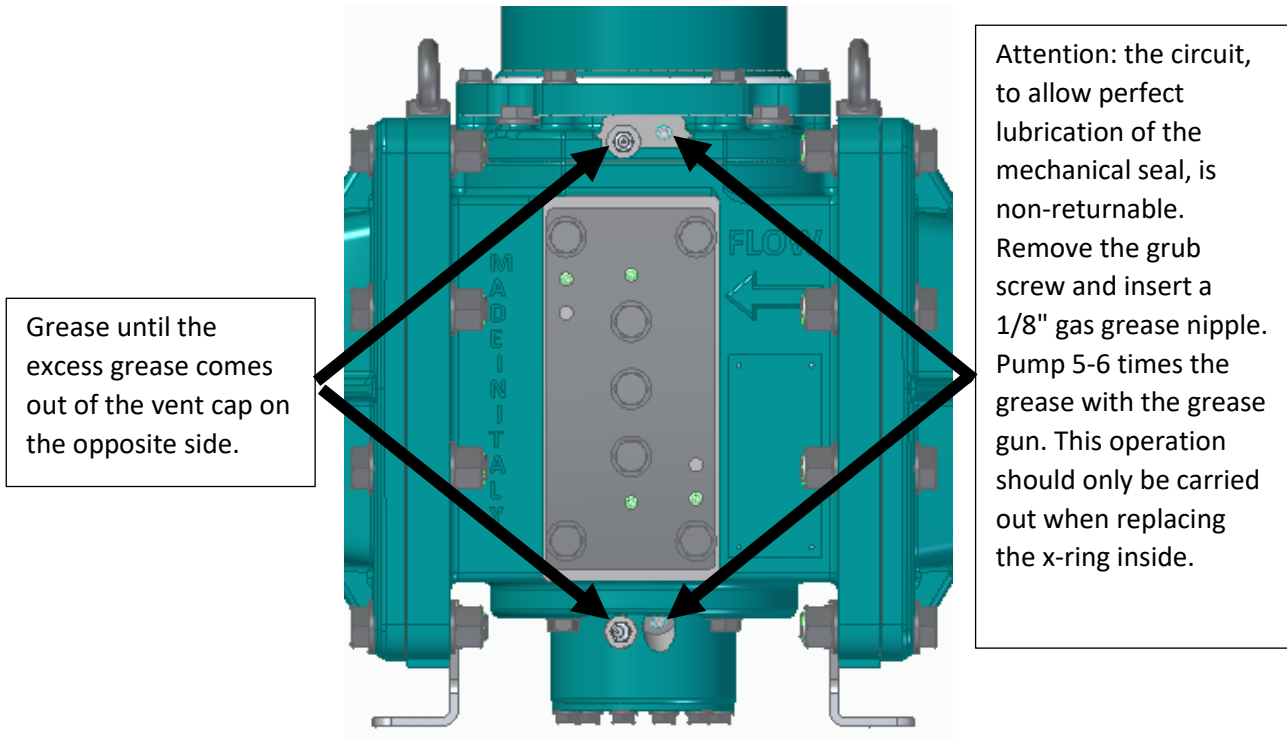

7.6 Routine Maintenance

Check the operation of the Emergency Stops once a month by running the machine idle and test that the emergency stops are correctly engaged. In the event of a malfunction, refer the fault finding only to qualified personnel or call the technical assistance of the manufacturer of the electrical panel. Check the continuity of the earthing circuit every 2 or 5 years by measuring the continuity in accordance with the provisions of the CEI 44-5 III Art.19 standard.

The machine has been designed to minimize routine maintenance, it is up to the operator to judge the condition and its suitability for use. It is recommended to stop and intervene with maintenance whenever you feel that it is not operating optimally, this will allow you to always have maximum efficiency. Visually check the condition of the individual parts that make up the machine, verifying that there are no alterations due to subsidence or deformation.

Warnings! Before each maintenance operation, the maintenance technician must turn off the power supply by acting on the main disconnect, close the padlock supplied with the electrical panel, and keep the key in his pocket

Always use the appropriate PPE – personal protective equipment:

- Gloves;
- Non-slip shoes;
- Suitable clothing;

7.7 Scheduled maintenance

These operations, although simple, must be carried out by qualified personnel. Scheduled ordinary maintenance includes inspections, checks and interventions that arrive at stops and breakdowns.

Comply with the following scheduled maintenance tasks for the Defender:

- Inspect the machine every month;
- Grease every 2000 working hours and replace the rotating mechanical seals once a year. Be careful when injecting grease: a high amount of grease could contaminate the materials being processed, and the breakage of rotating mechanical seals;
- Check every week for leaks;
- Check the lubrication status of the gearbox every month (see attached manual)
- Check the condition of the bolts every month.

Notes! Failure to comply with the requirements exonerates the manufacturer from any liability for the purposes of the warranty.

7.8 Extraordinary Maintenance

Extraordinary maintenance operations coincide with the possible breakage and therefore replacement of parts of the Defender.

Warnings! Disconnect the power source and insulate the machinery before proceeding with maintenance.

The following is how to disassemble and assemble the Defender:

7.8.1 Motor-Gearbox-Coupling

The replacement of the motor, gearbox and coupling can be carried out with the machinery on the piping line. To remove motor, gearbox and coupling, unscrew and remove bolts.



To mount, perform the previous actions in reverse.

7.8.2 Side knife

The replacement of the side knives can be done with the Defender mounted in line. The Side Knife is designed with two sharp sides. Consequently, with the first maintenance, it will be sufficient to turn the side knife upside down (pay attention to the groove on the external wall that indicates the first position). To reduce components and assembly errors, the side knives are interchangeable with each other.

To replace the side knife, proceed as follows:

- Remove the screws that hook the side knife to the Defender box (045-024);
- Equip yourself with two M10x40 screws, screw them into the appropriate holes, taking care to extract the counter-knife (015) in a straight direction;
- With a pin chaser, remove the straight pin (403) from the Defender box;
- Remove and replace the counter-knife o-ring (051);
- Rotate or replace the counter-knife (015), reposition it on the Defender box by matching the slots on it with the cage against the knife. Fix the screws in such a way as to allow small movements to the side knife;
- With a rubber mallet insert the straight pins (403), which will guarantee perfect centering, at this point tighten the screws firmly.

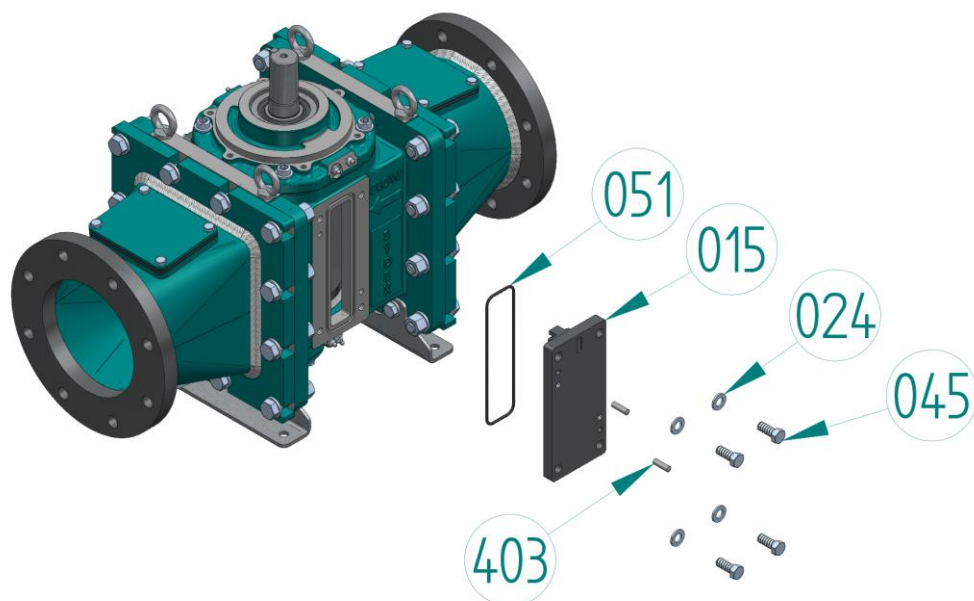

7.8.3 Cage vs Knife

To remove the cage against the knife you must remove the unit from the piping line. To lift the machine, use a hoist. Hook the lifting eyebolts of the Defender (053) to the hoist with ropes or special straps. Unscrew the flanges. Remove and transfer to a clean work area. Remove any screws that hold the Defender to the base.

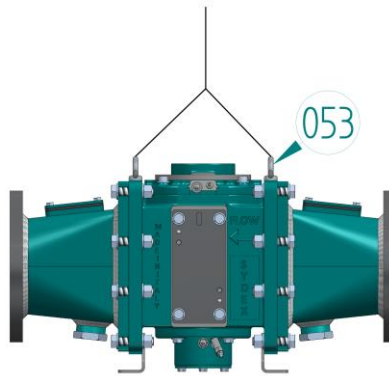

To replace the counter knife cage follow these instructions:

- Removes all screws (028) from the collector (008);
- Remove the collector (008);
- Remove the screws (042) from the counter-knife cage (022);
- Remove the worn cage against counter-knife cage (022);
- Remove and replace the collector o-ring (021);
- Reposition the new cage against the counter-knife cage (022) taking care to insert it correctly between the slots of the side blades;
- Tighten the screws (042) of the cage, replace the collector (008) and tighten the screws (028) firmly.

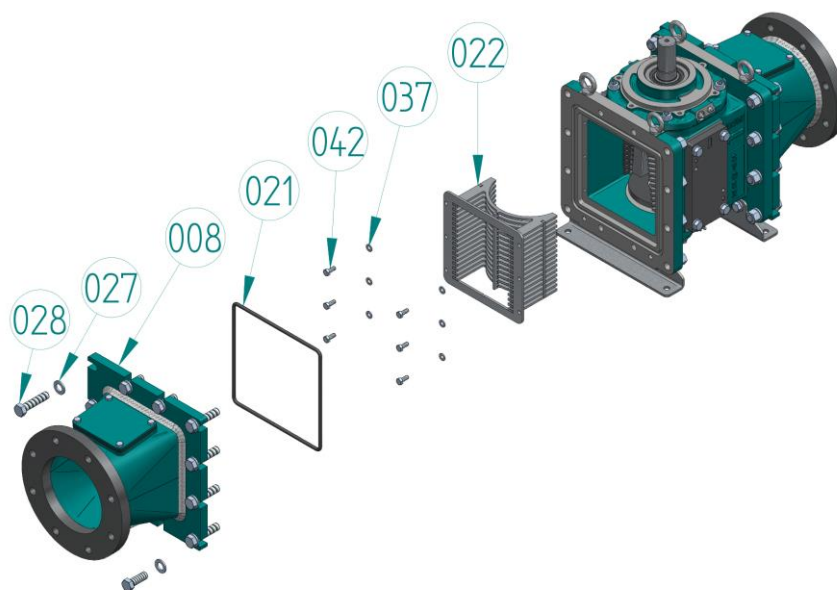

7.8.4 Rotary knife and mechanical seals

To replace the rotary knife and mechanical seals of must remove the unit from the piping line see paragraph 6.8.2. Remove the side knives and the cage against the knife. See sections **6.8.1** and **6.8.2**

Follow these instructions:

- Remove the screws (033) and grease nipples (004/A) from the lower bearing support (013);
- Remove screws (018) from the upper bearing support (014);
- Remove the knife assembly from the Defender box with the utmost care, for extraction it is advisable to hook a lifting ring to the shaft of the rotating knife using the special hole (M10).

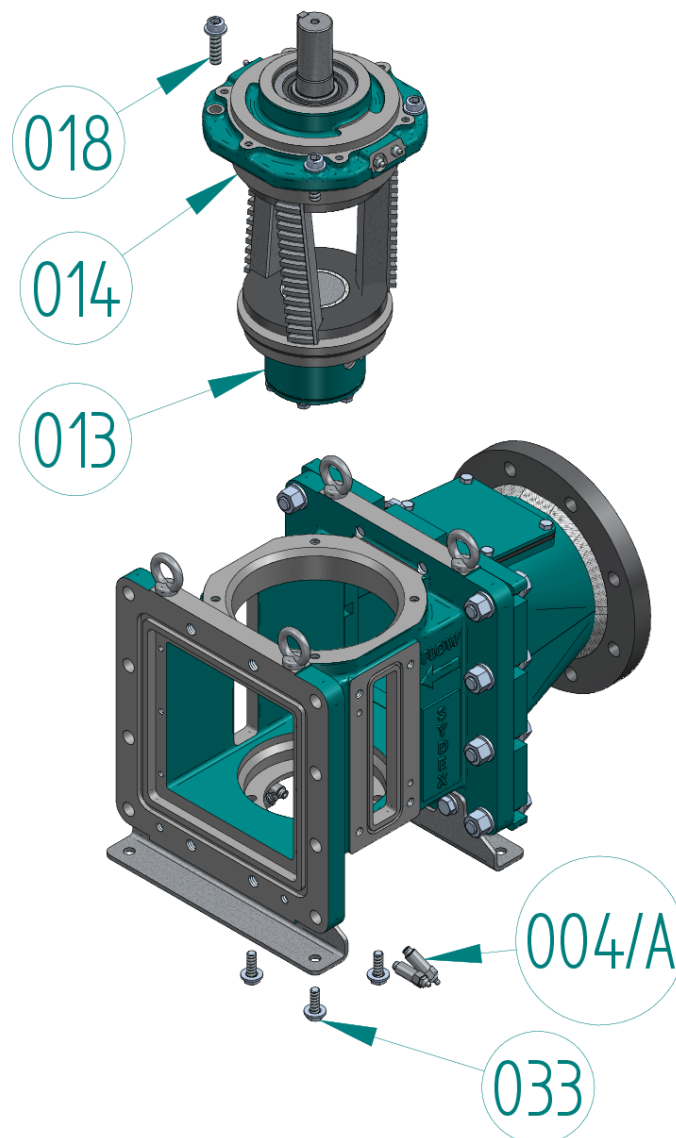

- Remove the shaft key (056) from the cutting shaft (011);
- Pull out the seeger ring (205), spacer ring (536), seeger ring (203) and spacer ring (537) in sequence;
- Slide off the upper bearing support (014)
- Remove the screws (020) from the bearing cover (003) of the lower bearing support (013);
- Remove the seeger ring (204) and the spacer ring (538).
- Slide off the lower bearing support (013)

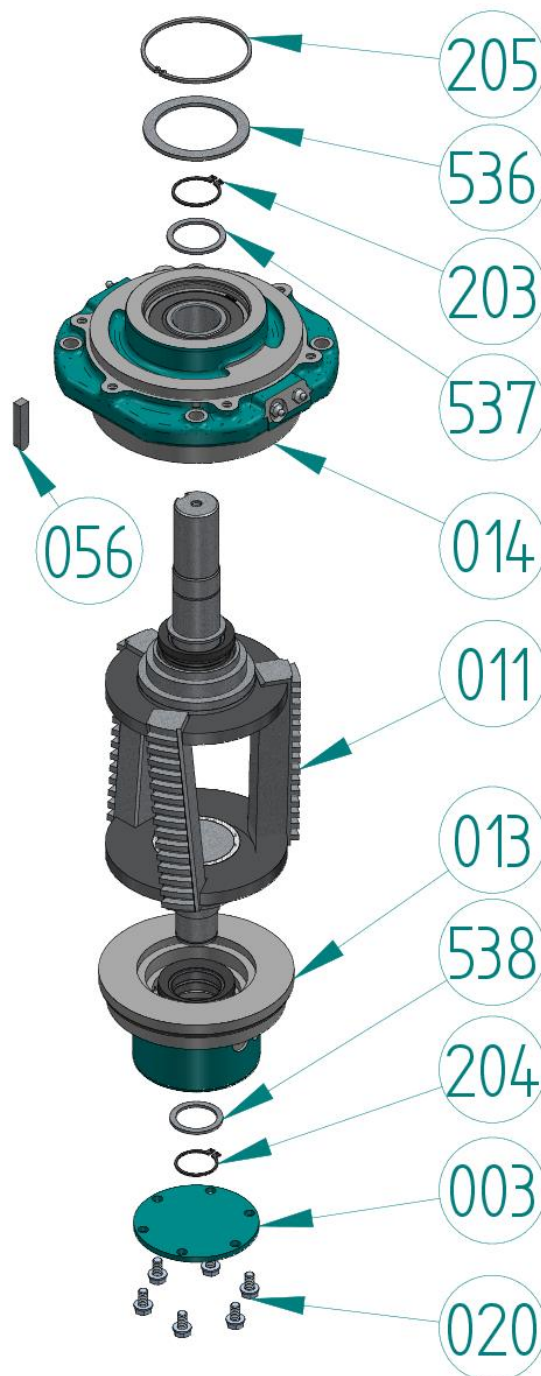

- Remove the bearing (238) from the upper bearing bearing (014), remove and replace the upper support o-ring (041);
- Remove the spacer ring (537) and seeger ring (203);
- Remove the mechanical seal (006) from the cutting shaft (011);
- Remove and replace bearing o-ring (019);
- Pull the bearing (239) out of the lower bearing support (013);
- Remove the spacer ring (538);
- Remove the mechanical seal (006).

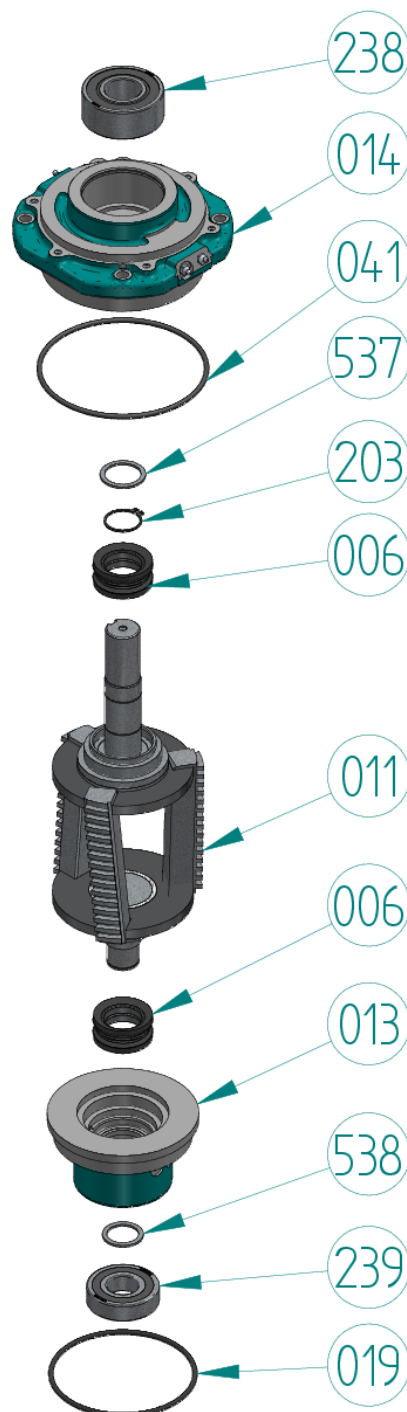

Notes! The assembly of the rotary knife and mechanical seals is a very delicate procedure. The use of hammers is strongly discouraged, the parts must be mounted without suffering any impact. A probable abrupt impact could cause the new mechanical seal to break or chip.

Proceed as follows for assembly:

- The mechanical seal is composed of two components called faces, a and they are mounted gaskets on the outside. Fit the rubber side face in the appropriate seat on the rotating shaft and on the lower bearing support, make sure that the rubber is correctly positioned. Insert the knife shaft into the lower bearing support or vice versa

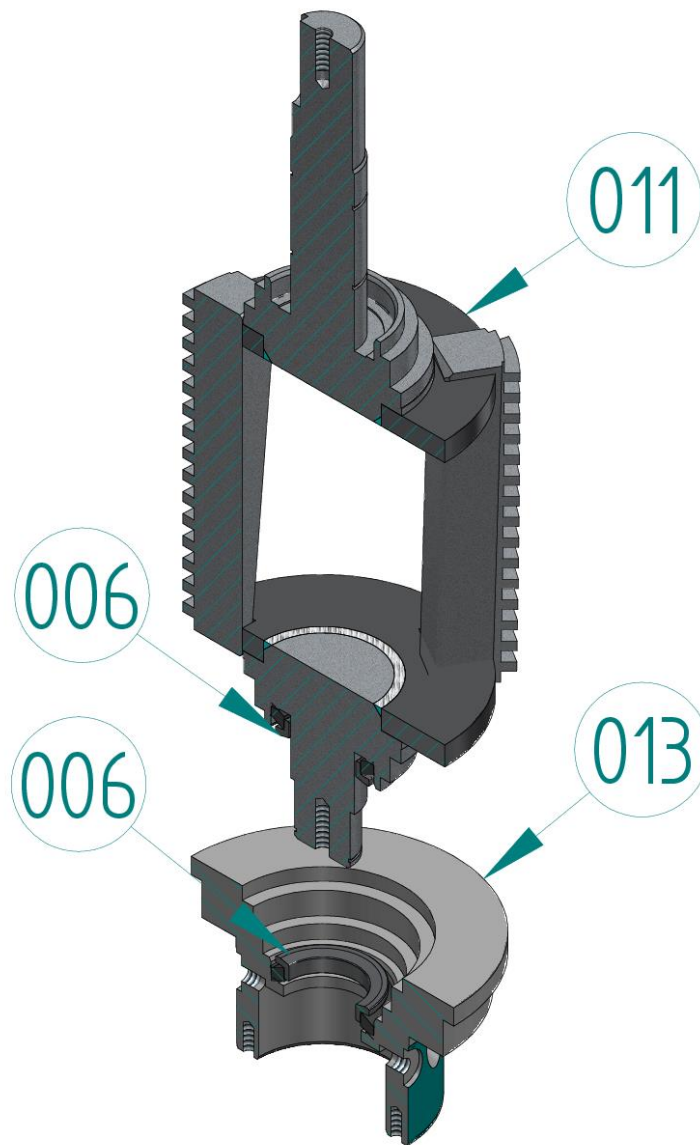

- Fit the spacer ring (538);
- Insert the bearing (239) taking care not to experience shocks;
- Assemble in sequence the spacer ring (538), seeger ring (204), the bearing cover (003) and tighten the screws (020). Then insert bearing o-ring (019)

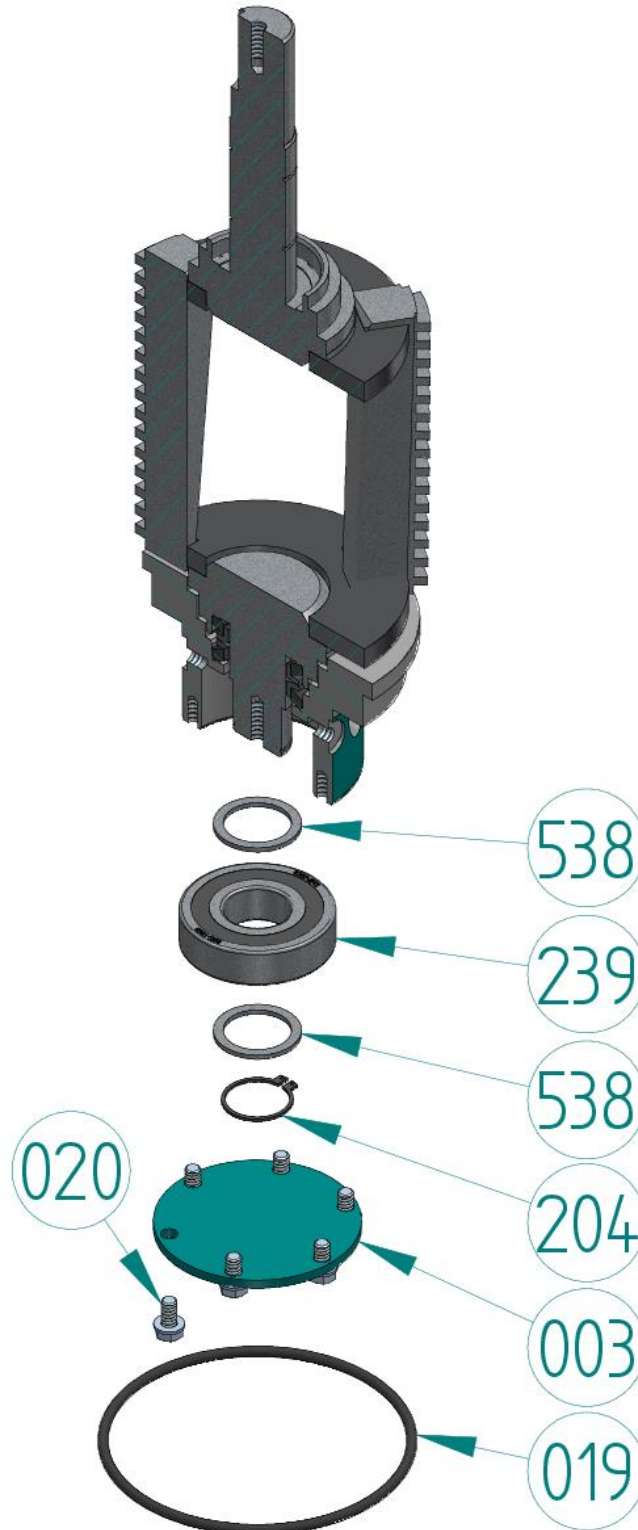

- Fit the face on the rubber side in the appropriate seat on the rotating shaft and on the upper bearing support, make sure that the rubber is correctly positioned. Insert the knife shaft into the lower bearing support or vice versa.

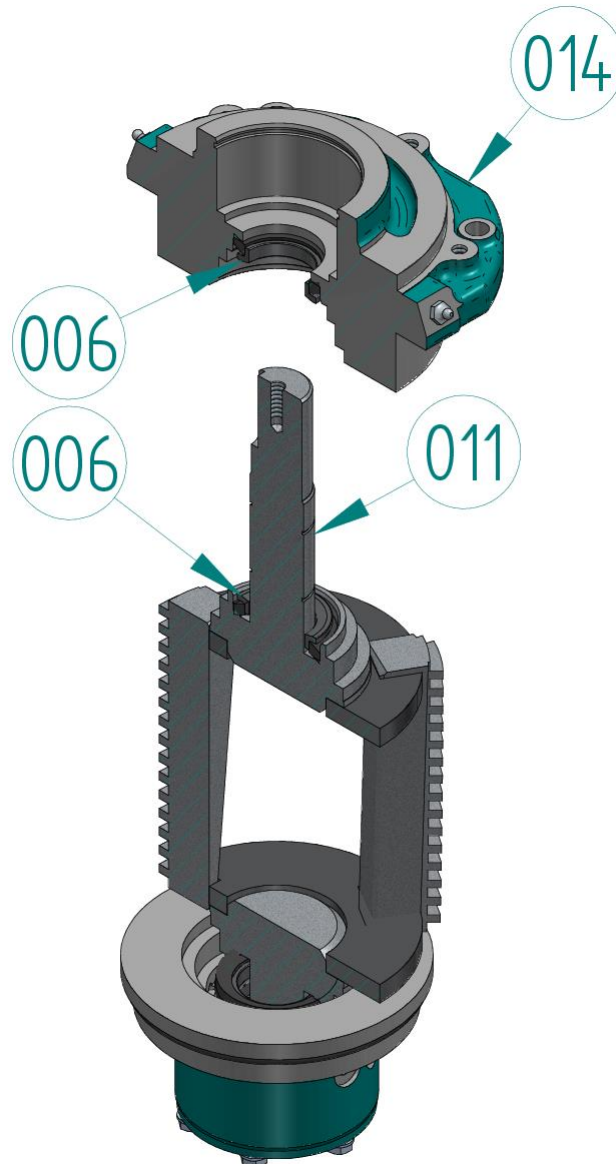

- Place the seeger ring (203) and spacer ring (537);
- Insert the bearing (238) taking care not to experience shocks;
- Place in sequence the spacer ring (537), seeger ring (203), spacer ring (536) and seeger ring (205);
- Insert the upper support o-ring (041) and the shaft key (056);
- Follow the reverse directions described in paragraph 6.8.3 – 6.8.2 – 6.8.1 to assemble the Defender.

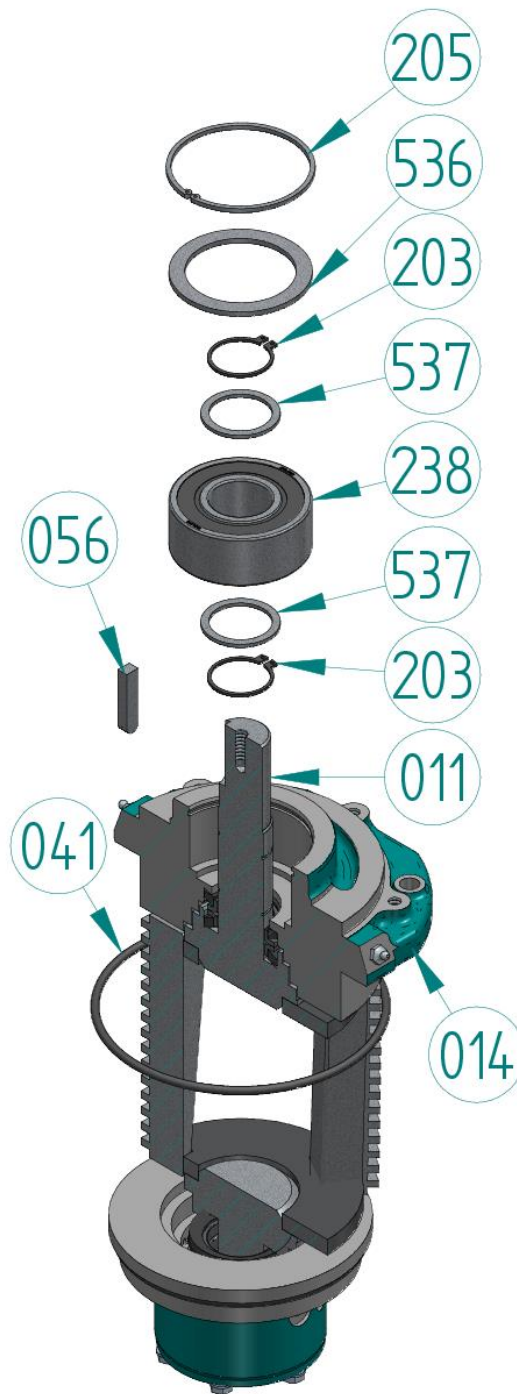

7.9 Diagnostics and troubleshooting

For defects or malfunctions of the machine not described in this manual, please contact the manufacturer.

PROBLEM	POSSIBLE SOLUTION
Engine won't start	Check the source of electricity. Check for overloads, check fuses, controls, etc.
The engine is noisy	The engine is damaged. Repair and/or replace it as directed.
The reducer is noisy	The gearbox is damaged, repair and/or replace it as indicated
Vibration	Realign the motor and motor assembly. Disconnect the power supply and check that there is no residual material inside the cage and the knife shaft. Remove large solids. Check the rotor balance.
Noise	Remove the rotor and foreign objects. Replace the rotor. Check the ventilation openings.
Noise	Replace bearings.
Fluid leakage	Identify the exact source of the leak. Check the sealing systems and replace it if worn. Check that the threaded cap is correctly positioned.
The control panel does not work	All control panels are set up and tested at the factory before shipment. Refer to the control panel manual.

8 Spare parts accessories

8.1 Assistance

For any type of information relating to the use, maintenance and installation of the machine, the manufacturer is always available. The customer should ask questions in clear terms, with references to this manual and the instructions listed.

8.2 Spare parts

For any replacement parts contact the manufacturer.

Always use original spare parts.

Notes! The manufacturer is not liable for breakages, malfunctions or damage to persons or property resulting from the use of parts of non-original parts.

For the management of spare parts, the manufacturer presents below a module that allows a quick identification of the part to be requested. The use of non-original spare parts is not recommended and, in the event that this occurs, the conditions of warranty (if still in force) and the manufacturer's responsibility in the use of the machine and any damage resulting from people and/or property are no longer applicable. To request spare parts, fill in the attached form, taking care to follow the instructions given therein.

Notes! It is advisable to faithfully reproduce the form in question (even photocopying it) in order to avoid any sort of error. Fill it in the table references as accurately as possible and send it to the manufacturer.

In order to interact in the most effective way with our technicians when ordering spare parts, please follow the following procedure:

- a) Call the company's spare parts service and describe the type of fault encountered;
- b) Describe the non-working part if necessary;
- c) Track down the part of the machine where the part is located;
- d) Order the part using the order form on the next page.

8.4 Recommended Replacement Parts

In general, all spare parts are available in our central warehouse. It is advisable to prepare a stock of some components of each machine to be kept in stock at the place where the machine is used.

Description	Quantity	Position
Shaft knife	1	011
Cage vs Knife	1	022
Mechanical Seals	2	006
Knife account	2	015
Gasket set	1	041/019/010/021/051
Bearings	1	238/239

9 Additional Instructions

9.1 Waste disposal

It will be the responsibility of the user, according to the laws in force in his country, to verify the correct disposal of the waste that the machine produces during processing. The disposal of lubricants and replaced parts such as electronic components, plastics, etc., must be carried out in compliance with the regulations in force in the country in which the machine is used.

9.2 Decommissioning and disposal

In the event that the machinery is stored or left to rest for some time, it is recommended that the shaft be resprayed with an anti-rust lubricant and that it be rotated monthly. The easiest way to rotate the shaft is to remove the motor cover and turn the fan.

The control panel, if supplied, should be stored in a dry environment to prevent moisture build-up from causing corrosion of contacts and other metal components. For the procedure for storing the motor, gearbox and control panel, consult the manufacturer's manual.

At the time of disposal, it is necessary to separate the plastic parts, metal parts and electrical components, which must be sent for separate collection in compliance with current legislation. As far as the metal mass of the machine is concerned, it is sufficient to divide it between the ferrous parts and those made of other metals or alloys, for a correct sending for recycling by casting.

9.3 Safe working procedures

With the help of what is reported in the use and maintenance manual, it is the responsibility of the employer to establish, where necessary, specific procedures and adequately inform the employees to:

- Safe use of the machine;
- Emergency situations;
- Procedure for maintenance work that requires the prevention of accidental restart (lotus procedure).

10 Attachments

10.1 Machine footprint drawings

10.1.1 Def190/DIN2501DN100PN16/HF482-90I

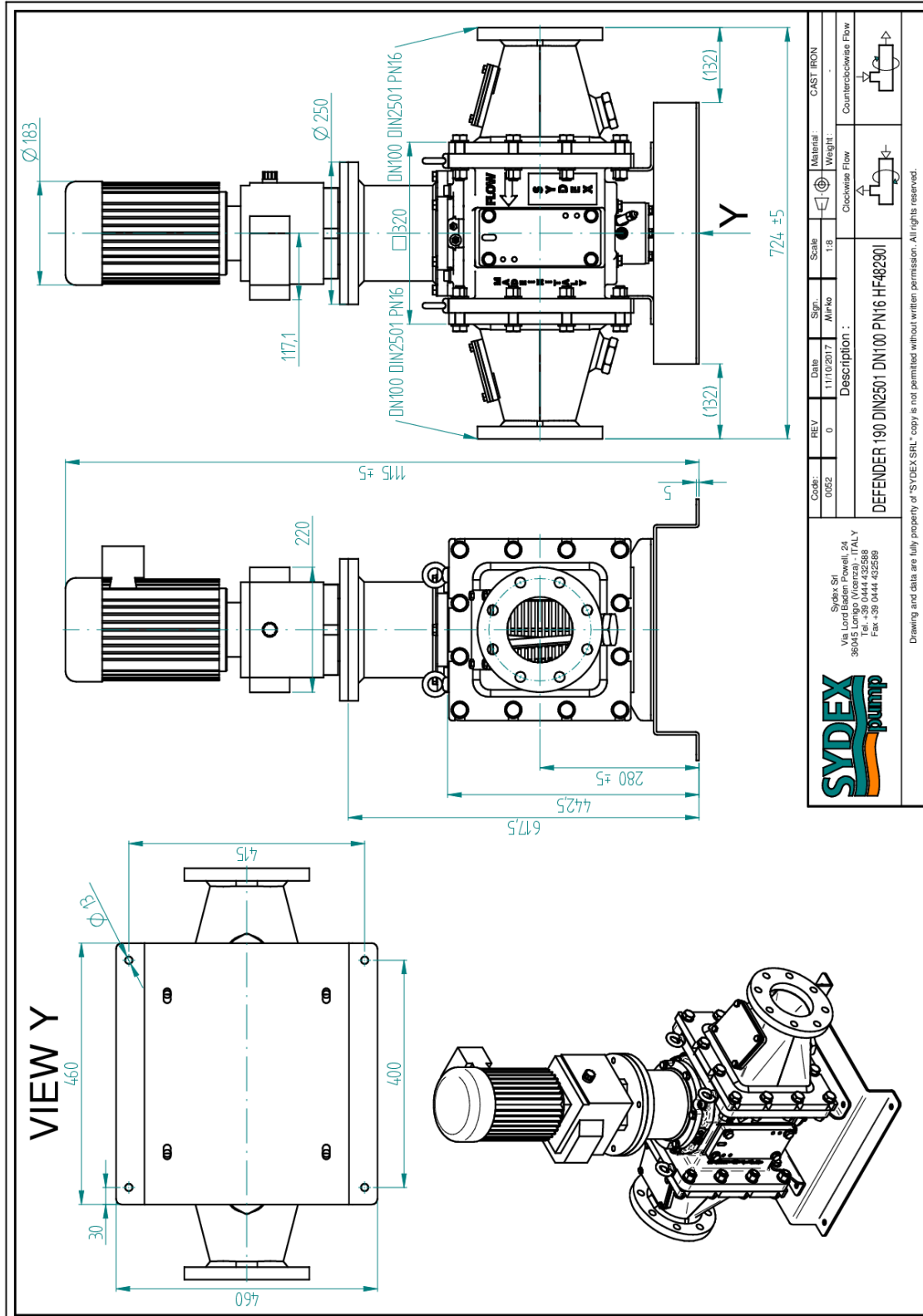

10.1.2 Def190/DIN2501DN100PN16/HF482-100J

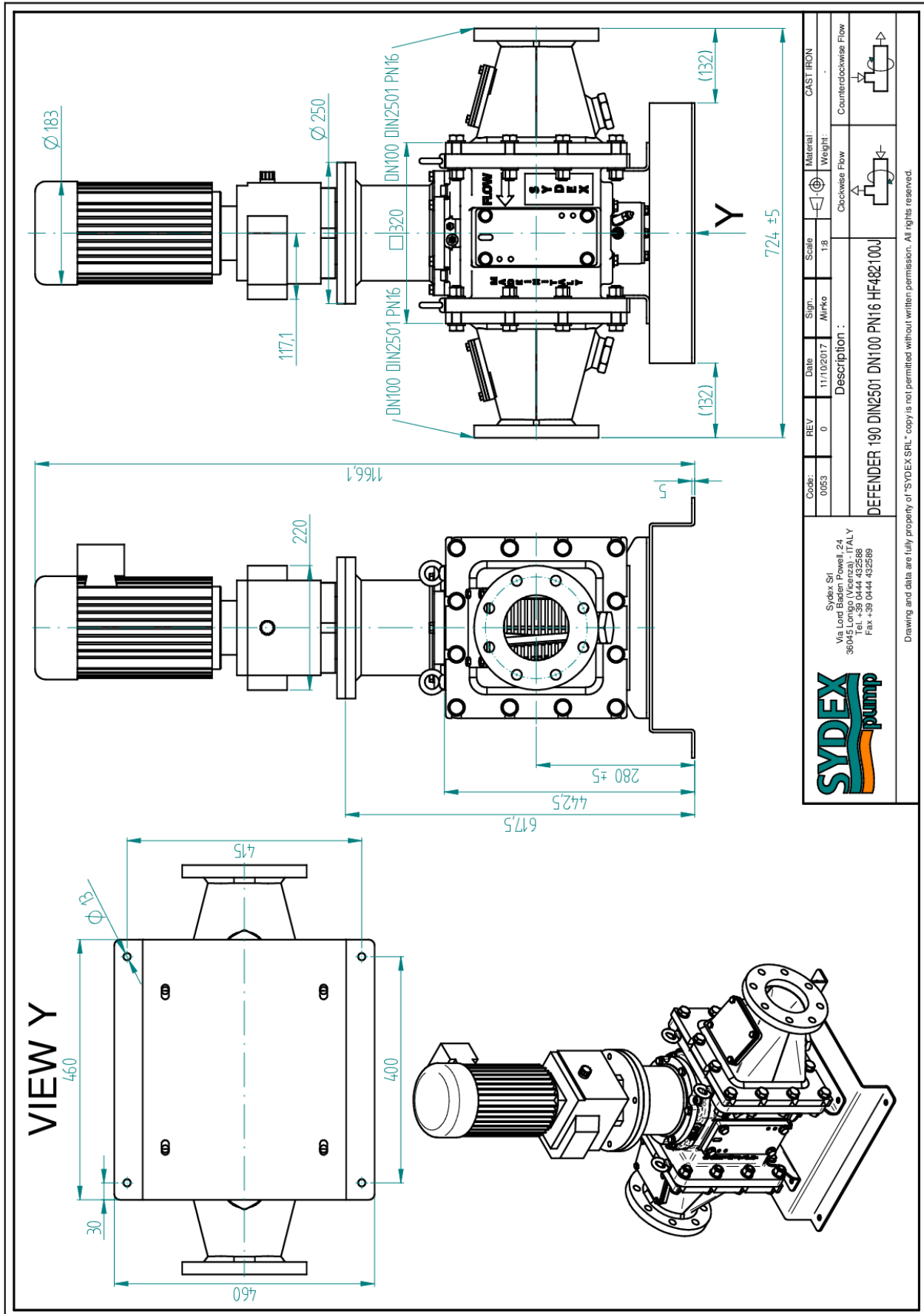

10.2 Exploded view machine drawing

ITEM NO.	QTY.	DESCRIPTION	CODE	ITEM NO.	QTY.	DESCRIPTION	CODE
001	1	BOX DEF	2D9004.003	536	1	RING SS 70X90X3.5	253046.001
003	1	BEARING COVER	2D9003.002	537	2	RING SS 40X50X2.5	253746.001
004	2	LUBRICATOR G1/8"	2D9004.001	538	2	RING SS 64X72.5	253746.001
004A	2	LUBRICATOR G1/8" LONG	2D9004A.001				
005	2	SUPPORT LEG	2D9005.001				
006	2	MECHANICAL SEALS	2D9006.001				
008	2	COLLECTOR RN380 DN50	2D9008.003				
009	2	INSPECTION PORT	2D9009.001				
010	2	SLASH GUARD RING	2D9010.001				
011	1	SHAFT	2D9011.001				
013	1	BEARING SUPPORT COVER	2D9013.002				
014	1	BEARING SUPPORT UPPER	2D9014.002				
015	2	AGAINST BLADE	2D9015.001				
018	4	SCREW M12X6 UNR27	2D9018.001				
019	1	O-RING O151.77 O53.4	2D9019.002				
020	14	SCREW M8X16					
021	2	O-RING O69.99 O69.99 COLLECTOR	2D9021.001				
022	1	CAGE	2D9022.003				
024	20	WASHER M12					
025	4	SCREW M12X30					
026	16	NUT M8					
027	40	WASHER M16					
028	16	SCREW M16X30					
029	6	SCREW M16X6					
033	3	SCREW M10X30					
037	12	WASHER M8					
039	6	WASHER M10					
041	1	O-RING O177.8 O153.4	2D9041.001				
042	6	SCREW M8X20					
044	8	SCREW M16X6					
045	8	SCREW M12X30					
051	2	AGAINST BLADE SEAL	2D9051.001				
053	4	EYE BOLTS M10					
054	2	HUBS					
055	1	ELASTOMER					
056	1	TAB					
071	1	COVER COUPLING	2D9071.003				
075	2	CAP	2D9075.001				
076	2	VENT CAP 1/8"					
077	2	CAP 1/8"					
203	2	SEGER UNIT 7435 - 40					
204	1	SEGER UNIT 7435 - 35					
205	1	SEGER UNIT 7437 - 90					
238	1	BEARING 308 2RS	213048.002				
239	1	BEARING 6307 2RS	213045.001				
403	4	PIN	240015.001				

SYDEX S.p.A.
Via Lancia, 10 - 30045 Lugo (Verona) - ITALY
Tel. +39 0445 425288
Fax. +39 0445 425281

Date: 11/10/2017 Sign: MFRKO
Description: DEFENDER 190-150.02 DIN
Code: 0029

SYDEX pump

Drawing and data are the property of SYDEX S.p.A. and are not permitted without written permission. All rights reserved.

10.3 Oil data sheet

MULTIS EP 2



Multi purpose extreme pressure lithium grease

APPLICATIONS

Multi purpose EP grease

General Lubrication

Recommendation

- MULTIS EP 2 is a true multi purpose grease, formulated for lubrication of loaded slide-, ball-, and roller-bearings, wheel bearings, universal joints, chassis, and various shock loaded or vibrating applications in transport, agriculture and off road equipment, operating in wet, dusty and/or dry conditions.
- Suitable as general purpose grease for industrial applications requiring a NLGI 2 grade
- extreme Pressure grease.
- Always avoid contamination of the grease by dust and/or dirt when applying. Preferably use a pneumatic pump system or cartridges.

ADVANTAGES

Durable film

Miscible
Mechanical stability

Thermal stability
No harmful substances

- Because of its true Multi Purpose character MULTIS EP 2 may replace a wide range of greases, allowing stock rationalization and simplification of maintenance.
- Forms a durable lubrication film, resulting in reduction of maintenance and down-time costs.
- Miscible with most other conventional soap greases.
- Excellent mechanical stability avoiding ejection or loss of consistency during operation.
- Excellent adhesion to metal.
- Good thermal stability, leading to high resistance to temperature variations.
- MULTIS EP 2 does not contain lead, or other heavy metals considered harmful to human health and the environment.

CHARACTERISTICS

	METHODS	UNITS	MULTIS EP 2
Soap/ Thickener		-	Lithium
NLGI Grade	ASTM D 217/DIN 51 818	-	2
Colour	Visual	-	Dark brown
Appearance	Visual	-	Smooth
Operating Temperature range		°C	-25 to 120
Penetration @ 25 °C	ASTM D 217/DIN51 818	0.1 mm	265-295
Four ball weld load	DIN 51 350-4	daN	260-280
Anti-rust performance SKF- EMCOR	DIN 51 802/IP220/NFT 60-135/ISO 11007	rating	0-0
Dropping point	IP 396/DIN ISO 2176	°C	>190
Kinematic viscosity of the base oil at 40°C	ASTM D 445/DIN 51 562-1/ISO 3104/IP71	mm ² /s (cSt)	200

The typical characteristics mentioned represent mean values

SPECIFICATIONS

ISO 6743-9: L-XBCEB 2
DIN 51 502: KP2K -25

TOTAL LUBRICANTS
P.O. Box : 52288
Dubai, United Arab Emirates
1/1

MULTIS EP 2
N° TDS/DXB/09/10/331



This lubricant used in accordance with our recommendations and for the application for which it is intended does not represent a special hazard. A safety data file conforming to the requirements of current E.U. legislation is available from your local trade consultant.

10.4 Electrical panel maintenance user manual

SD D P PUMP: GRINDER CONTROL PANEL WITH PLC REVERSE ROTATION CONTROL.
FRONT VIEW PANEL AND CONTROLS

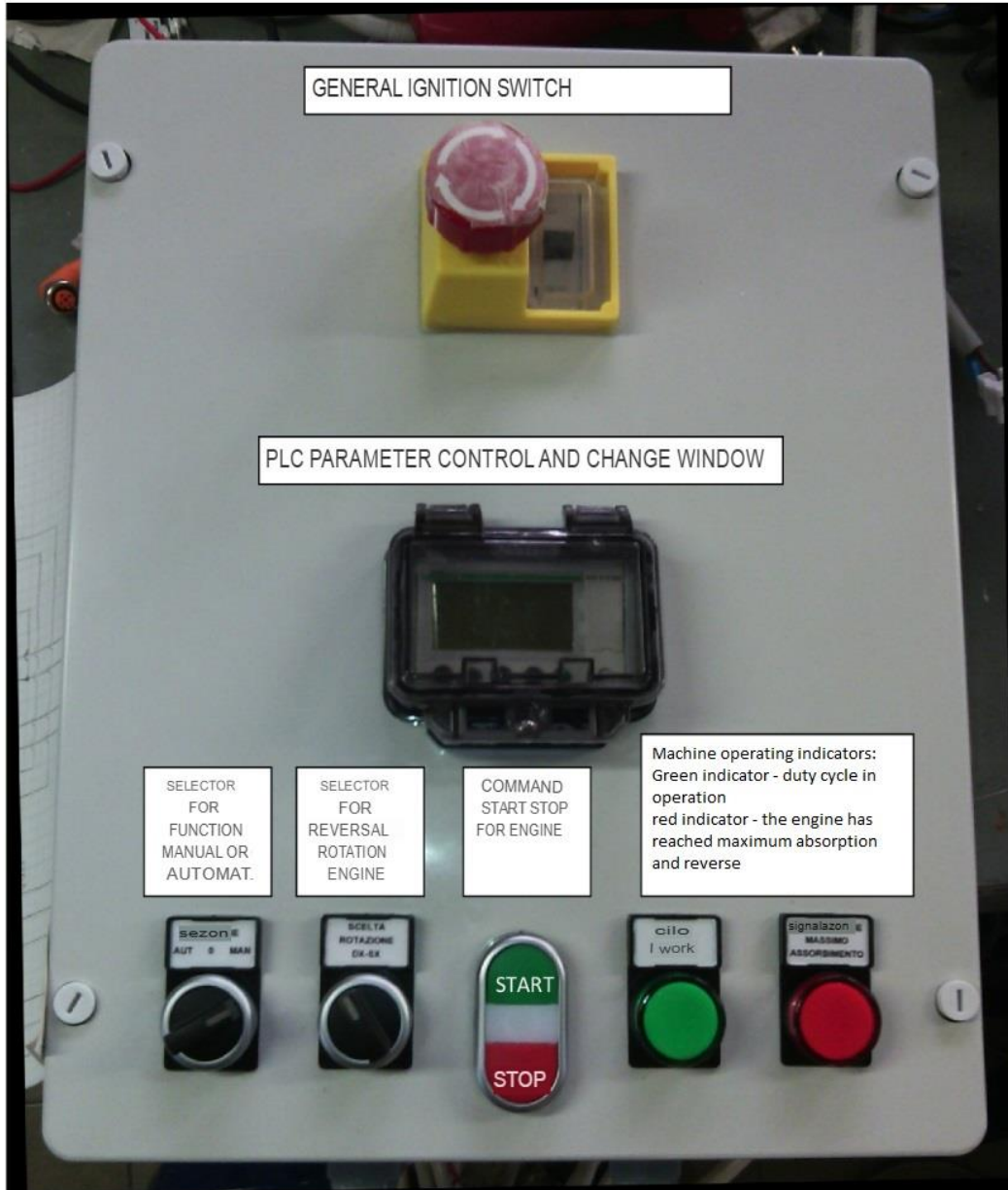

TO START THE MACHINE: PRESS THE BLACK BUTTON OF THE MAIN SWITCH (WITH THE MUSHROOM BUTTON UNLOCKED) AND THEN SELECT THE TYPE OF CYCLE THAT THE MACHINE NEEDS TO DO : --- BY PRESSING START (GREEN BUTTON) IN MANUAL MODE, THE MACHINE ALWAYS TURNS IN THE SELECTED DIRECTION UNTIL THE OPERATOR GIVE THE STOP (RED BUTTON).
--- AUTOMATIC: PRESSING START THE MACHINE STARTS THE WORKING CYCLE BY REVERSING THE DIRECTION OF TRAVEL EVERY TIME THE MOTOR EXCEEDS THE SET MAXIMUM CURRENT. AFTER 4 CYCLES OF CONTINUOUS INVERSION, THE MACHINE STOPS. CAN YOU STOP THE CYCLE WHEN YOU WANT BY PRESSING STOP OR THE MUSHROOM BUTTON OF THE MASTER SWITCH.

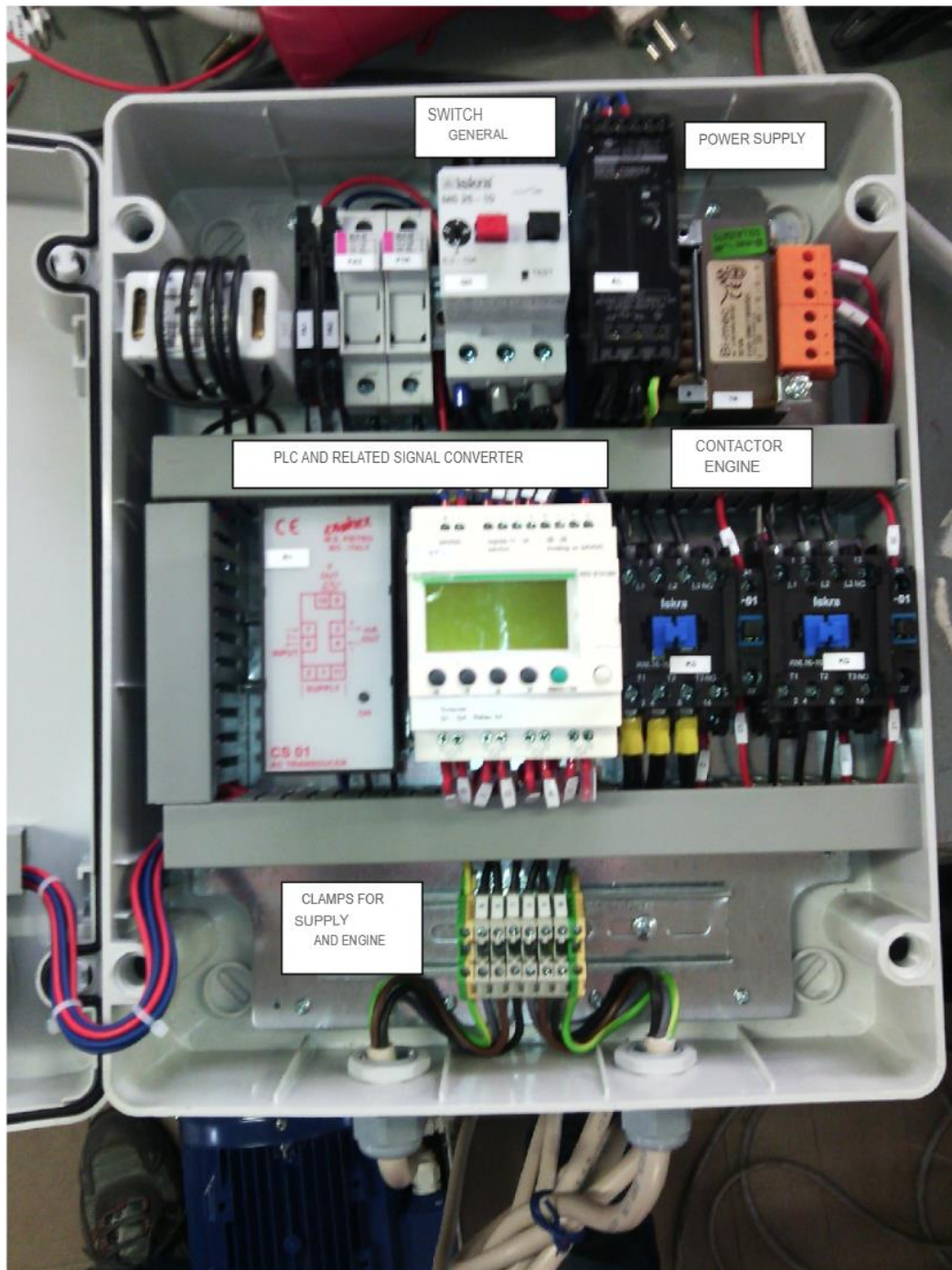

INTERNAL VIEW COMPONENTS AND CONNECTIONS



How to change the parameters of work on the plc:

Put the man-o-aut selector in position o

Press button 4 and 6 simultaneously to enter the programming menu and the first line will start blinking

To select the data line to change press 1 or 4

To change the data you are interested in press 2 or 3

To save the new value press button 5

The data that can be changed are:

- Motor tripping threshold current (up to 6 a max)
- Cycle number exchange rotation
- Motor pause time for automatic reverse gear

To start the duty cycle select manual or automatic and press the green button.

Working cycle automatically the green lamp flashes at the end of the cycle and remains fixed.

The red lamp signals the achievement of the set load threshold of the motor current.

To reset the cycle or stop the machine press the red button.

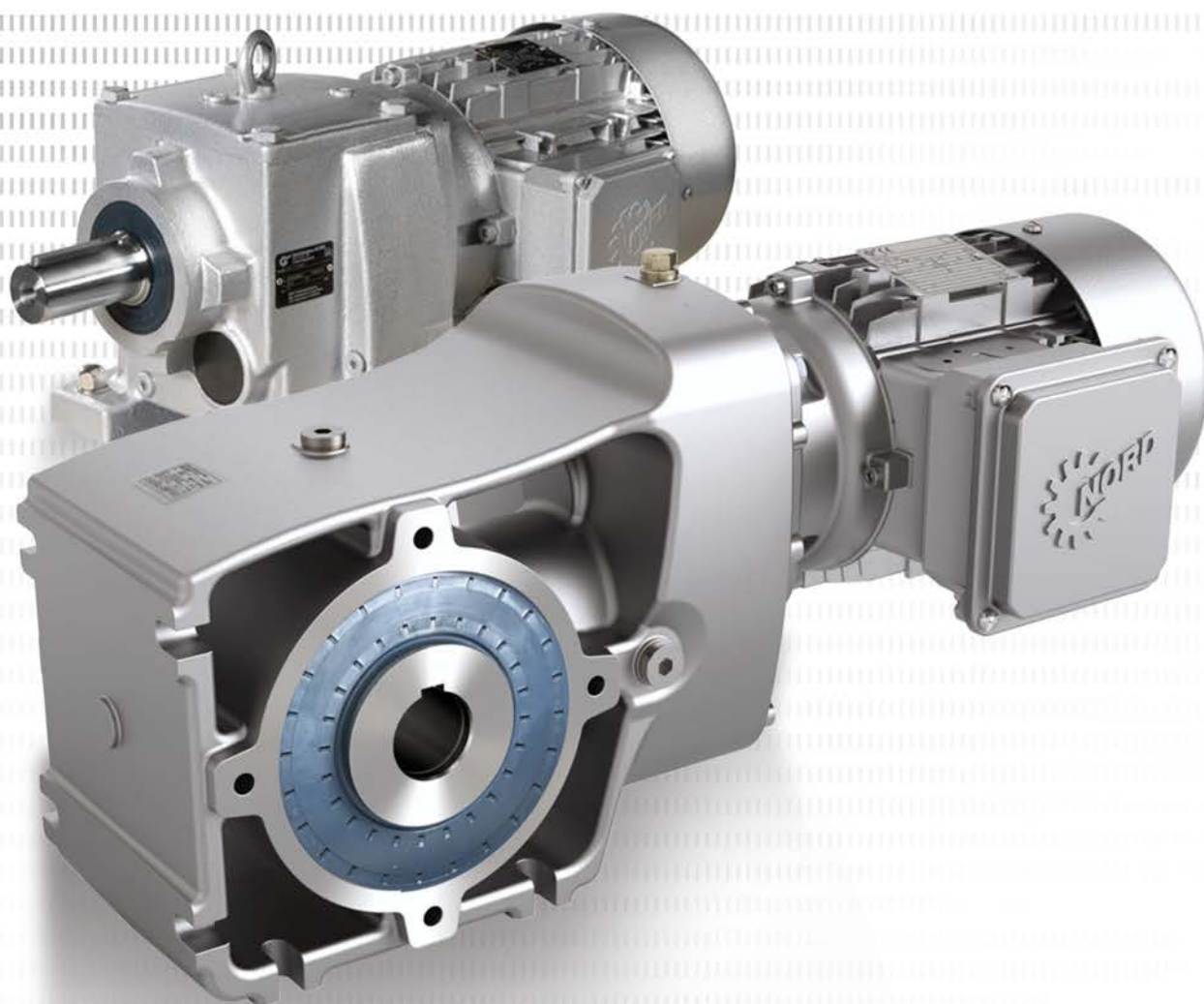

B 1000 – en

Gear units

Manual with installation instructions





Read document and keep for future reference

Read this document carefully prior to performing any work on or putting the device into operation. It is essential to read and observe the instructions in this document. They serve as the prerequisite for smooth and safe operation and the fulfilment of any warranty claims.

Contact Getriebebau NORD GmbH & Co. KG if your questions regarding the handling of the device are not answered in this document or if you require further information.

The German version of this document is the original. The German document is always decisive. If this document is available in other languages, this will be a translation of the original document.

Keep this document in the vicinity of the device so that it is available if required.

Use the version of this documentation that is valid for your device at the time of delivery. You can find the currently valid version of the documentation under www.nord.com.

Please also note the following documents:

- Gear unit catalogues,
- Documentation for the electric motor,
- Documentation for equipment which is attached or provided.

Documentation

Designation: **B 1000**
 Part no.: **6052802**
 Series: Gear units and geared motors
 Type series:
 Gear unit types: **Helical gear unit**
 NORDBLOC.1® helical in-line gear unit
 Standard helical gear unit
 Parallel shaft gear unit
 Bevel gear unit
 Helical worm gear unit
 MINIBLOC worm gear unit
 UNIVERSAL worm gear unit

Version list

Title, Date	Order number / Version	Remarks
	Internal code	
B 1000 , February 2013	6052802 / 0713	-
B 1000 , September 2014	6052802 / 3814	<ul style="list-style-type: none"> • General corrections
B 1000 , April 2015	6052802 / 1915	<ul style="list-style-type: none"> • New gear unit types SK 10382.1 + SK 11382.1
B 1000 , March 2016	6052802 / 0916	<ul style="list-style-type: none"> • General corrections • New bevel gear units SK 920072.1 + SK 930072.1
B 1000 , September 2016	6052802 / 3816	<ul style="list-style-type: none"> • General corrections • New helical gear units SK 071.1, SK 171.1, SK 371.1, SK 571.1, SK 771.1
B 1000 , June 2018	6052802 / 2518	<ul style="list-style-type: none"> • General corrections • New parallel shaft gear units SK 0182.1, SK 0282.1, SK 1282.1, SK 1382,1 • New worm gear unit SK 02040.1
B 1000 , December 2018	6052802 / 5018	<ul style="list-style-type: none"> • General corrections • Revision of safety and warning information • New NORDBLOC.1® helical in-line gear units SK 871.1, SK 971.1, SK 1071.1
B 1000 , October 2019	6052802 / 4419	<ul style="list-style-type: none"> • General corrections • Addition of GRIPMAXX™ (option M)

Title, Date	Order number / Version	Remarks
	Internal code	
B 1000 , September 2021	6052802 / 3921	<ul style="list-style-type: none"> • Editorial revision • General corrections and amendments
	32551	
B 1000 , July 2022	6052802 / 2822	<ul style="list-style-type: none"> • Revision of the maximum motor weights
	34343	
B 1000 , July 2023	6052802 / 3023	<ul style="list-style-type: none"> • General corrections • Revision of safety information • Enhancement of types in table “Maximum permitted motor weights”: SK 9xxx.1 and SK 1382.1 • Revision of lubricants • Adjustment of long-term storage
	36228	
B 1000 , June 2024	6052802 / 2424	<ul style="list-style-type: none"> • General corrections • Addition of gear unit types SK 1282.1 GJL, SK 1382.1 and SK 1382.1 GJL • Enhancement of types in table “Maximum permitted motor weights”: SK 971.1 and SK 1071.1 • Revision of lubricants
	38062	

Table 1: Version list B 1000

Copyright notice

As an integral component of the device described here, this document must be provided to all users in a suitable form.

Any editing or amendment or other utilisation of the document is prohibited.

Publisher

Getriebebau NORD GmbH & Co. KG

Getriebebau-Nord-Straße 1 • 22941 Bargteheide, Germany • <http://www.nord.com>

Fon +49 (0) 45 32 / 289-0 • Fax +49 (0) 45 32 / 289-2253

Member of the NORD DRIVESYSTEMS Group

Table of Contents

1	Safety information	10
1.1	Intended use	10
1.2	Do not make any modifications	10
1.3	Performing inspection and maintenance work	10
1.4	Personnel qualification	10
1.5	Safety for particular activities	11
1.5.1	Check for transport damage	11
1.5.2	Safety information for installation and maintenance	11
1.6	Hazards.....	11
1.6.1	Hazards when lifting	11
1.6.2	Hazards due to rotating parts	11
1.6.3	Hazards due to high or low temperatures.....	12
1.6.4	Hazards due to lubricants and other substances.....	12
1.6.5	Hazards due to noise.....	12
1.6.6	Hazards due to pressurised coolants	12
2	Description of gear units	13
2.1	Gear unit types and type designations	13
2.2	Name plate.....	15
3	Transport, storage, assembly	16
3.1	Transporting the gear unit	16
3.2	Storage and downtimes	16
3.2.1	General measures	16
3.2.2	Storage and downtimes in excess of 3 months	17
3.2.3	Storage and downtimes of more than 9 months	17
3.3	Preparing for installation	18
3.3.1	Check for damages	18
3.3.2	Remove corrosion protection agents	18
3.3.3	Check rotational direction	18
3.3.4	Check ambient conditions	18
3.3.5	Drives with nsd tupH surface treatment.....	18
3.3.6	Installing the oil expansion chamber (Option: OA).....	19
3.3.7	Installing the oil reservoir tank (Option: OT)	19
3.4	Installing the gear unit.....	20
3.5	Installation of a hub on solid shaft (option: V, L)	21
3.6	Fitting push-on gear units with fastening element (option: B).....	23
3.7	Fitting a hollow shaft with shrink disc (Option: S).....	26
3.8	Fitting a hollow shaft with GRIPMAXX™ (Option: M).....	28
3.9	Fitting the covers (option: H, H66).....	30
3.10	Fitting the covers.....	31
3.11	Fitting a standard motor (Option: IEC, NEMA, AI, AN).....	32
3.12	Mounting of the cooling coil onto the cooling system	36
3.13	Installation of the external oil/air cooler	36
3.13.1	Connecting hose lines	37
3.13.2	Electrical connection.....	37
3.14	Installation of an oil expansion chamber (Option: OA)	38
3.14.1	Installation of the sizes I, II and III	38
3.14.2	Installation of sizes 0A and 0B.....	39
3.15	Subsequent painting	39
3.16	Electrical connection of the mounted motor	39
4	Commissioning	40
4.1	Checking the oil level	40
4.2	Activating the vent.....	40
4.3	Activating the automatic lubricant dispenser	41
4.4	Cooling coil (Option: CC)	43
4.5	External oil/air cooler.....	44
4.6	Running-in time for the worm gear unit	44

4.7	AI/AN adapter operation with option BRG1	45
4.8	Checklist	45
5	Service and maintenance	46
5.1	Inspection and maintenance intervals	46
5.2	Service and maintenance work	47
5.2.1	Visual inspection for leaks	47
5.2.2	Check for running noises	47
5.2.3	Checking the oil level	48
5.2.4	Visual inspection of the rubber buffers (Option: G, VG)	48
5.2.5	Visual inspection of the hoses (Option: OT, CS2-X)	49
5.2.6	Re-greasing (Option: VL2, VL3, W, AI, AN)	49
5.2.7	Replacing the automatic lubricant dispenser	49
5.2.8	Change the oil	50
5.2.9	Clean and check vent screw	51
5.2.10	Replacing the shaft sealing ring	51
5.2.11	Re-lubrication of bearings in the gear unit	51
5.2.12	General overhaul	51
6	Disposal	52
7	Appendix	53
7.1	Versions and mounting position	53
7.1.1	Explanation of symbols	53
7.1.2	UNIVERSAL/MINIBLOC worm gear units	54
7.1.3	Parallel shaft gear units with oil level tank	55
7.1.4	Overview of mounting positions	56
7.2	Lubricants	69
7.2.1	Roller bearing greases	69
7.2.2	Gear oils	70
7.3	Screw tightening torques	72
7.4	Troubleshooting	73
7.5	Leakage and leak-tightness	74
7.6	Repair information	75
7.6.1	Repairs	75
7.6.2	Internet information	75
7.7	Warranty	75
7.8	Abbreviations	76

List of illustrations

Figure 1: Name plate	15
Figure 2: Example of a simple pulling device	21
Figure 3: Permissible application of force to drive and driven shafts	22
Figure 4: Applying lubricant to the shaft and the hub.....	23
Figure 5: Removing the factory-fitted closing cap.....	24
Figure 6: Gear unit mounted on shaft with a shoulder using the fastening element	24
Figure 7: Gear unit mounted on shaft without a shoulder using the fastening element	24
Figure 8: Removal using dismantling device	24
Figure 9: Mounting the rubber buffer (Option G and/or VG) on parallel shaft gear units	25
Figure 10: Attaching the torque support on bevel gear and worm gear units	25
Figure 11: Hollow shaft with shrink disc.....	26
Figure 12: GRIPMAXX™, exploded diagram	28
Figure 13: Fitting the covers, Option SH, Option H, and Option H66.....	30
Figure 14: Disassembly and assembly of the cover cap.....	31
Figure 15: Fitting the coupling onto the motor shaft - various types of coupling	34
Figure 16: Cooling cover	36
Figure 17: Connection of the oil/air cooler	37
Figure 18: Position of the oil expansion chamber	38
Figure 19: Position of the oil expansion chamber	39
Figure 20: Activating the vent screw	40
Figure 21: Activating the pressure vent screw	40
Figure 22: Removing the vent plug and fitting the special pressure vent.....	41
Figure 23: Fitting the grease collection container	41
Figure 24: Activating the automatic lubricant sensor with standard motor mounting	42
Figure 25: Adhesive label	42
Figure 26: Checking the oil level with a dipstick	48
Figure 27: Re-grease IEC/NEMA adapters AI and AN with option BRG1	49
Figure 28: Switching the automatic lubricant sensor with standard motor mounting	49
Figure 29: Parallel shaft gear units with oil level tank	55

List of tables

Table 1: Version list B 1000.....	4
Table 2: Gear unit types and type designations.....	13
Table 3: Versions and options	14
Table 4: Permissible machine shaft tolerances	29
Table 5: Motor weights IEC motors	32
Table 6: Motor weights NEMA motors	33
Table 7: Motor parallel keys.....	35
Table 8: Position of the half-coupling on the NEMA motor shaft.....	35
Table 9: Checklist for commissioning	45
Table 10: Inspection and maintenance intervals.....	46
Table 11: Materials	52
Table 12: Roller bearing greases.....	69
Table 13: Gear oils	70
Table 14: Screw tightening torques	72
Table 15: Overview of malfunctions.....	73
Table 16: Definition of leakage according to DIN 3761.....	74

1 Safety information

1.1 Intended use

These gear units are used to transmit rotary movements. They convert velocity and torque. They are intended for use as part of a drive system in commercially used plant and machinery. The gear units must not be operated until it has been established that the plant or machinery can be safely operated with the gear unit. Suitable protective measures must be provided if failure of a gear unit or a geared motor could result in a risk to persons. The plant or machinery must comply with local legislation and directives. All applicable health and safety requirements must be met. In particular, the Machinery Directive 2006/42/EC and UKCA "Supply of Machinery (Safety) Regulations 2008" must be especially observed in the relevant areas of application.

The gear units and geared motors to which this manual with installation instructions refers to are usually components for installation in machines according to the current EC Machinery Directive 2006/42/EG.

In certain individual cases in which the gear unit or the geared motor is considered as a ready-to-install drive system for specific applications, this drive system is classified as a incomplete machine according to the current EC Machinery Directive 2006/42/EG. A corresponding declaration of incorporation is enclosed with the product.

The gear units may not be used in environments in which an explosive atmosphere can occur.

The gear units may only be used according to the information in the technical documentation from Getriebebau NORD GmbH & Co. KG. Damage to the gear unit may result if the gear unit is not used as intended and according to the information in the operating and installation manual. This may also result in personal injury.

The base or the gear unit mount must be appropriately dimensioned for the weight and torque. All of the fastenings provided must be used.

Some gear units are equipped with a cooling coil/cooling system. These gear units may only be operated if the cooling circuit is connected and in operation.

1.2 Do not make any modifications.

Do not make any structural modifications to the gear unit. Do not remove any protective guards. Do not change the original coating / paint or apply additional coatings / paints.

1.3 Performing inspection and maintenance work

Due to lack of maintenance and damage, malfunctions may occur which can result in personal injury.

- Carry out all servicing and maintenance work at the specified intervals.
- Also note that servicing is necessary after long storage periods prior to commissioning.
- Do not operate damaged gear units. The gear unit must not have any leaks.

1.4 Personnel qualification

All transport, storage, installation, commissioning and maintenance work must be carried out by qualified specialist personnel.

Qualified specialist personnel are persons who have the training and experience to recognise and avoid any possible risks.

1.5 Safety for particular activities

1.5.1 Check for transport damage

Transport damage may cause malfunctions of the gear unit, which may cause personal injury. Oil which escapes due to leaks may cause a slipping hazard.

- Check the packaging and the gear unit for transport damage.
- Do not operate damaged gear units.

1.5.2 Safety information for installation and maintenance

Before starting work on the gear unit disconnect the drive from the power supply and secure it against accidental switch-on. Allow the gear unit to cool down. Depressurise the cooling circuit lines.

Damaged or defective components, attachment adapters, flanges and covers may have sharp edges. Wear work gloves and work clothing.

1.6 Hazards

1.6.1 Hazards when lifting

Persons may be injured by falling or swinging gear units. Therefore also observe the following information:

- Cordon off a wide area around the hazard area. Take care that there is adequate space to avoid swinging loads.
- Never stand under suspended loads.
- Use adequately dimensioned means of transport which are suitable for the purpose. The weight of the gear unit can be obtained from the type plate.
- Only lift the gear unit by the factory-mounted eyebolts.

If there are no eyebolts available, screw one eyebolt according to DIN 580 into each provided threaded hole. The eyebolts must be fully screwed in.

Tighten the eyebolts only according to Chapter 3.1 "Transporting the gear unit". Only use the eyebolts to lift the gear unit without other components. The eye bolts are not designed for lifting the gear unit with attachments. Use the eyebolts on both the gear unit and the motor to lift a geared motor (observe the manufacturer's instructions for the motor).

1.6.2 Hazards due to rotating parts

Rotating parts cause a risk of entanglement. This may lead to severe injuries such as crushing or strangling.

- Provide contact protection. In addition to shafts, this also applies to fans as well as drives and driven elements such as belt drives, chain drives, shrink discs and couplings. Take possible run-on of the machine into consideration for the design of protective devices.
- Do not operate the drive without covers or hoods.
- Secure the drive to prevent activation during installation and maintenance work.
- For test operation do not switch on the drive without an installed driven element or secure the motor shaft key.
- Also observe the safety information in the operating and installation instructions provided by manufacturers of components supplied.

1.6.3 Hazards due to high or low temperatures

The gear unit may heat up to 90 °C during operation. Touching hot surfaces or contact with hot oil may result in burns. At very low ambient temperatures freezing may occur on contact.

- Only touch the gear unit when wearing gloves after operation or at very low ambient temperatures.
- Before starting maintenance work, allow the gear unit to cool down sufficiently after operation.
- Provide a contact guard if there is a risk that persons may touch the gear unit when it is in operation.
- Bursts of hot oil mist may be emitted from the pressure vent screw during operation. Provide a suitable guard so that persons cannot be injured by this.
- Do not place any flammable materials on the gear unit.

1.6.4 Hazards due to lubricants and other substances

Chemical substances which are used with the gear unit may be toxic. Eye injuries may result if these substances enter the eyes. Lubricants and adhesives may cause skin irritation.

Oil mist may escape when vent screws are opened.

Due to lubricants and conservation materials, gear units may be slippery and slip out of the hands. There is a slipping hazard from spilled lubricants.

- When working with chemical substances wear chemical-resistant gloves and work clothing. Wash your hands after working.
- Wear protective goggles if there is a possibility of splashed chemicals, for example when filling oil or during cleaning work.
- If chemicals enter the eyes, rinse with large amounts of cold water immediately. Consult a physician in case of symptoms.
- Observe the safety data sheets for the chemicals. Keep the safety data sheets in the vicinity of the gear unit.
- Collect spilled lubricants immediately with a binding agent.

1.6.5 Hazards due to noise

Some gear units or attached components may cause hazardous noise levels during operation. Wear hearing protection if work has to be carried out close to such gear units.

1.6.6 Hazards due to pressurised coolants

The cooling system is under high pressure. Damage or opening a cooling line which is under pressure may result in injury. Depressurise the cooling circuit before working on the gear unit.

2 Description of gear units

2.1 Gear unit types and type designations

Gear unit types / Type designations
UNICASE helical in-line gear unit 2-stage: SK 02, SK 12, SK 22 SK 32, SK 42, SK 52, SK 62N, SK 62, SK 72, SK 82, SK 92, SK 102 3-stage: SK 03, SK 13, SK 23, SK 33N, SK 43, SK 53, SK 63, SK 73, SK 83, SK 93, SK 103
NORDBLOC.1® helical in-line gear unit 1-stage: SK 071.1, SK 171.1, SK 371.1, SK 571.1, SK 771.1, SK 871.1, SK 971.1, SK 1071.1 2-stage: SK 072.1, SK 172.1, SK 372.1, SK 572.1, SK 672.1, SK 772.1, SK 872.1, SK 972.1 3-stage: SK 373.1, SK 573.1, SK 673.1, SK 773.1, SK 873.1, SK 973.1
STANDARD helical gear unit 2-stage: SK 0, SK 01, SK 20, SK 25, SK 30, SK 33 3-stage: SK 010, SK 200, SK 250, SK 300, SK 330
UNICASE parallel gear unit 2-stage: SK 0182NB, SK 0182.1, SK 0282NB, SK 0282.1, SK 1282, SK 1282.1, SK 1282.1 GJL, SK 2282, SK 3282, SK 4282, SK 5282, SK 6282, SK 7282, SK 8282, SK 9282 3-stage: SK 1382.1, SK 1382.1 GJL, SK 2382, SK 3382, SK 4382, SK 5382, SK 6382, SK 7382, SK 8382, SK 9382, SK 10382, SK 10382.1, SK 11382
UNICASE bevel gear unit 3-stage: SK 9012.1, SK 9016.1, SK 9022.1, SK 9032.1, SK 9042.1, SK 9052.1, SK 9062.1, SK 9072.1, SK 9082.1, SK 9086.1, SK 9092.1, SK 9096.1 4-stage: SK 9013.1, SK 9017.1, SK 9023.1, SK 9033.1, SK 9043.1, SK 9053.1
NORDBLOC.1® bevel gear unit 2-stage: SK 920072.1, SK 92072.1, SK 92172.1, SK 92372.1, SK 92672.1, SK 92772.1, SK 930072.1, SK 93072.1, SK 93172.1, SK 93372.1, SK 93672.1, SK 93772.1
UNICASE worm gear unit 2-stage: SK 02040, SK 02040.1, SK 02050, SK 12063, SK 12080, SK 32100, SK 42125 3-stage: SK 13050, SK 13063, SK 13080, SK 33100, SK 43125
UNIVERSAL SI worm gear unit 1-stage: SK 1SI31, SK 1SID31, SK 1SI40, SK 1SID40, SK 1SI50, SK 1SID50, SK 1SI63, SK 1SID63, SK 1SI75 2-stage (helical worm gear unit): SK 2SID40, SK 2SID50, SK 2SID63
UNIVERSAL SMI worm gear unit 1-stage: SK 1SMI31, SK 1SMID31, SK 1SMI40, SK 1SMID40, SK 1SMI50, SK 1SMID50, SK 1SMI63, SK 1SMID63, SK 1SMI75 2-stage (helical worm gear unit): SK 2SMID40, SK 2SMID50, SK 2SMID63

Table 2: Gear unit types and type designations

Double gear units consist of two single gear units. The type designation of the SK 73/22 double gear unit, for example, means that the double gear unit consists of the single gear units SK 73 and SK 22.

Abbreviation	Description
(without)	Foot mounting with solid shaft
/31	Worm gear first stage
/40	Worm gear first stage
5	Reinforced output shaft
A	Hollow shaft
AI	Standard IEC motor attachment
AI...BRG1	Standard IEC motor attachment with manual re-lubrication
AI...RLS	Standard IEC motor attachment with integrated back stop
AL	Reinforced axial bearing
AN	Standard NEMA motor attachment
AN...BRG1	Standard NEMA motor attachment with manual re-lubrication
AN...RLS	Standard NEMA motor attachment with integrated back stop
B	Fastening element
CC	Cooling coil
D	Torque arm
DR	Pressure vent
EA	Splined hollow shaft
F	B5 flange
G	Rubber buffer for torque arm
H	Cover cap
/H10	Modular helical pre-stage for universal worm gear units
H66	IP66 cover
IEC	Standard IEC motor attachment
K	Torque bracket
L	Solid shaft both sides
M	GRIPMAXX™
MK	Motor bracket
NEMA	Standard NEMA motor attachment
OA	Oil expansion chamber
OT	Oil level tank
R	Back stop
S	Shrink disc
SCP	Screw conveyor flange
SO1	Synthetic oil ISO VG 220
V	Solid shaft (for standard helical gear units: reinforced drive)
VG	Reinforced rubber buffer
VI	Viton radial shaft seals
VL	Reinforced output bearings
VL2	Agitator version - Reinforced bearings
VL3	Agitator version - Reinforced bearings - Drywell
VS	Reinforced shrink disc
W	Free drive shaft
X	Housing foot mounting
Z	B14 flange

Table 3: Versions and options

2.2 Name plate

The name plate must be firmly attached to the gear unit and must not be subjected to permanent soiling. Please contact the NORD service department if the name plate is illegible or damaged.

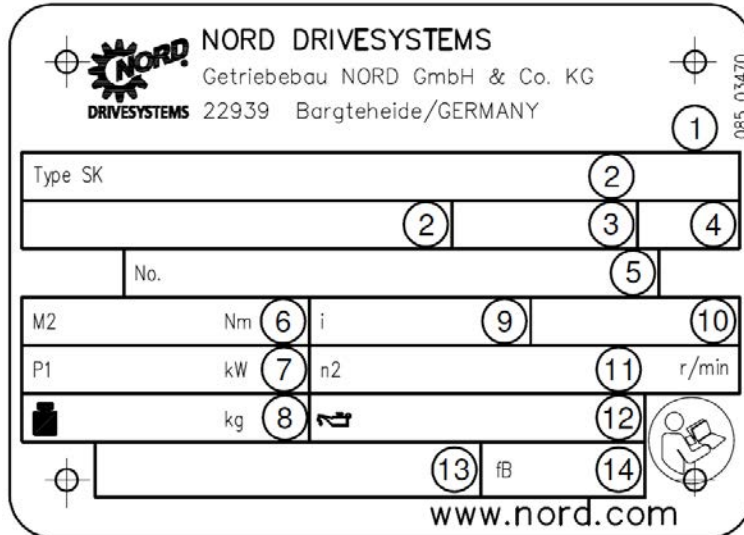

Figure 1: Name plate

Explanation

1	DataMatrix code	8	Weight
2	NORD gear unit type	9	Overall gear unit ratio
3	Operating mode	10	Installation position
4	Year of manufacture	11	Rated speed of gear unit output shaft
5	Serial number	12	Lubricant type, viscosity and quantity
6	Rated torque of gear unit output shaft	13	Customer part number
7	Drive power	14	Operating factor

3 Transport, storage, assembly

3.1 Transporting the gear unit

WARNING

Hazard due to falling loads

- The thread of the eyebolt must be fully screwed in.
- As shown in the illustration to the right, only lift on the eyebolts vertically to the female thread and not more oblique than 45° to the vertical.
- Note the centre of gravity of the gear unit.

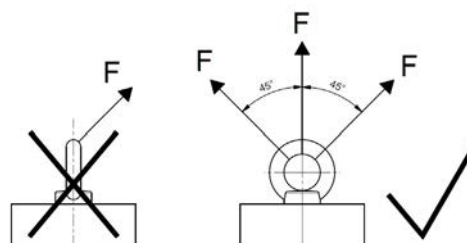

Only use the eyebolts attached to the gear unit for transport. If geared motors have an additional eyebolt attached to the motor, this must also be used.

Transport the gear unit with care. Impacts to the free ends of shafts may cause internal damage to the gear unit.

No additional loads must be attached to the gear unit.

Use suitable aids such as cross-beams or similar to facilitate the attachment or transportation of the gear unit. Gear units without eyebolts may only be transported with shackles and lifting straps or chains at an angle of 90° to 70° to the horizontal.

3.2 Storage and downtimes

3.2.1 General measures

- Store the gear unit in a dry space, relative humidity less than 60%.
- Store the gear unit at a temperature in the range of – 5 °C to + 50 °C without severe temperature fluctuations.
- Do not expose the gear unit to direct sunlight or UV light.
- There must be no aggressive or corrosive substances (contaminated air, ozone, gases, solvents, acids, alkalis, salts, radioactivity etc.) in the immediate vicinity.
- The gear unit must not be exposed to vibration or oscillation.
- Store the gear unit in the mounting position (see chapter 7.1 "Versions and mounting position"). Secure it against falling.

3.2.2 Storage and downtimes in excess of 3 months

Note the following measures in addition to Section 3.2.1 "General measures".

- Repair damages to the coating. Check if a corrosion protection agent has been applied to the flange bearing surfaces, the shaft ends and the unpainted surfaces. If required, apply a suitable corrosion protection agent to the surfaces.
- Seal all openings on the gear unit.
- The output shaft must be rotated by at least one revolution every 3 months so that the contact position of the gear teeth and the roller bearings are changed.

3.2.3 Storage and downtimes of more than 9 months

Under certain conditions, storage of 2 to 3 years is possible. The specified storage duration is only approximate. The actual storage duration depends on the local conditions. Note the following measures in addition to Sections 3.2.1 "General measures" and 3.2.2 "Storage and downtimes in excess of 3 months".

Gear units can be supplied prepared for long-term storage. The gear units are completely filled with lubricant, or a VCI corrosion protection agent is added to the gear oil. The adhesive label on the housing shows the respective information.

Conditions of the gear unit and storage area for long-term storage prior to commissioning:

- Store the gear unit at a temperature in the range of -5 °C to +40 °C without severe temperature fluctuations.
- Check if the sealing cord in the vent screw is in place. It must not be removed during storage.
- Store the gear unit in a dry space. With a relative humidity less than 60%, the gear unit can be stored for up to 2 years; with a relative humidity less than 50%, storage of up to 3 years is possible.
- In tropical regions, protect the gear unit against damage by insects.
- Gear unit components such as motors, brakes, couplings, belt drive, and cooling units must be protected for a long-term storage in accordance to their operating instructions.

In addition to the preparations listed in 4 "Commissioning", the following measures are necessary before commissioning:

- Check the gear unit for external damage.
- After storage of more than 2 years, or with storage temperatures outside the permissible range from -5 °C to +40 °C, change the lubricant and the radial shaft seals in the gear unit before commissioning.
- If the gear unit is completely filled, the oil level must be reduced according to the mounting position. For the lubricant quantity and lubricant type, refer to the information on the name plate.
- For the option with manual re-lubrication, change the bearing grease after a storage period of more than two years. The service life of the grease is reduced after a storage time or gear unit shutdown of more than 9 months (see chapter 5.2.6 "Re-greasing (Option: VL2, VL3, W, AI, AN)").

3.3 Preparing for installation

3.3.1 Check for damages

Please examine the delivery for transport and packaging damage immediately on receipt. Pay particular attention to radial shaft seals and sealing caps. Report any damage to the carrier immediately.

Do not put the drive into operation if damage such as leaks are visible.

3.3.2 Remove corrosion protection agents

All bare metal surfaces and shafts of the drive are protected with corrosion protection agents before shipping.

Thoroughly remove corrosion protection agents and any dirt (e.g. colour residues) from all shafts, flange surfaces and gear unit attachment surfaces before assembly.

3.3.3 Check rotational direction

If an incorrect rotational direction may result in damage or potential risk, check for the correct rotational direction of the output shaft during a test run before attaching it to the machine. Ensure the correct rotational direction during operation.

For gear units with an integrated back stop, switching the drive motor to the blocked direction of rotation, may result in damage to the gear unit. Gears with integrated back stops are marked with arrows on the drive/driven sides. The arrows point in the rotation direction of the gear unit. When connecting the motor and during motor control, ensure, e.g. by testing the field of rotation, that the gear unit can only operate in the direction of rotation.

3.3.4 Check ambient conditions

Make sure that no aggressive or corrosive substances which attack metal, lubricants or elastomers are present at the installation site or are subsequently expected during operation. If such substances are to be expected, contact Getriebebau NORD.

The gear unit, especially its radial shaft seals should be protected from exposure to direct sunlight.

The standard permissible ambient temperature range for synthetic gear unit oils (CLP PG ... and CLP HC...) is -20 °C to $+40\text{ °C}$. This temperature range can be extended according to the lubricant table (see chapter 7.2.2 "Gear oils"), if all mounted materials of the gear unit and the application-related speed, torques and modes of operation allow this. Note the project planning documents of the order for this. In case of doubt, ask Getriebebau NORD.

For mineral oil (CLP), the permissible ambient temperature range in accordance to the above stated lubricant table is restricted. The lubricant type is indicated on the name plate (see chapter 2.2 "Name plate").

For installation altitudes above 1000 m above sea level, the permissible speed and torques may be reduced. Note the project planning documents of the order for this. In case of doubt, ask Getriebebau NORD.

3.3.5 Drives with nsd tupH surface treatment

Drives with **nsd tupH** surface treatment must be electrically decoupled from other components by the use of non-conductive intermediate layers in order to prevent galvanic corrosion.

3.3.6 Installing the oil expansion chamber (Option: OA)

Mount the oil expansion chamber (Option OA) according to Chapter 3.14 "Installation of an oil expansion chamber (Option: OA)".

3.3.7 Installing the oil reservoir tank (Option: OT)

Mount the oil reservoir tank (Option OT) according to document WN 0-521 30.

A pressure vent is optionally available. If available, screw the M12x1.5 pressure relief vent into the oil reservoir tank.

3.4 Installing the gear unit

NOTICE!

Gear unit damage through overheating

- For geared motors, check that the cooling air from the motor fan can circulate around the gear unit without obstruction.

NOTICE

Damage of bearing and gear wheel

- Do not carry out any welding work on the gear unit.
- Do not use the gear unit as earth connection for welding work.

The following conditions must be met at the installation site in order to prevent overheating during operation:

- There must be adequate space around the gear unit.
- Air must be able to flow freely past all sides of the gear unit.
- For geared motors, the cooling air from the motor fan must be able to circulate around the gear unit without obstruction.
- The gear unit must not be enclosed or encased.
- The gear unit must not be exposed to high energy radiation.
- Do not direct warm exhaust air from other units onto the gear unit.
- The base or flange to which the gear unit is attached must not input any heat into the gear unit during operation.
- Do not allow dust to accumulate in the area of the gear unit

Install the gear unit in the correct mounting position (see chapter 7.1 "Versions and mounting position"). **Oil checking and oil drain screws must be accessible.**

The base or flange to which the gear unit is fitted should be vibration-free, torsionally rigid and flat. The flatness of the bolting surface on the base or flange must comply with DIN ISO 2768-2 tolerance class K.

Precisely align the gear unit with the drive shaft of the machine in order to prevent additional forces from being imposed on the gear unit due to distortion.

Fasten the gear unit to all gear unit feet of one side or to all flange holes. Use bolts with a minimum quality of 8.8. Tighten the bolts with correct torques (see chapter 7.3 "Screw tightening torques").

For foot and flange-mounted gear units (Option XZ or XF), ensure tension-free bolting. The foot mounting is used to fasten the gear unit. It is designed to absorb the reaction forces from the torque, radial and axial forces as well as the weight. B5 or B14 flanges are basically not designed to absorb the reaction forces. In case of doubt, contact Getriebebau NORD for investigation of the particular case.

Earth the gear unit housing. For geared motors, ensure the earthing via the motor connection.

3.5 Installation of a hub on solid shaft (option: V, L)

NOTICE

The gear unit may be damaged by axial forces.

Bearings, gearwheels, shafts and housings may be damaged by incorrect fitting.

- Use a suitable pulling device.
- Do not hit the hub with a hammer.

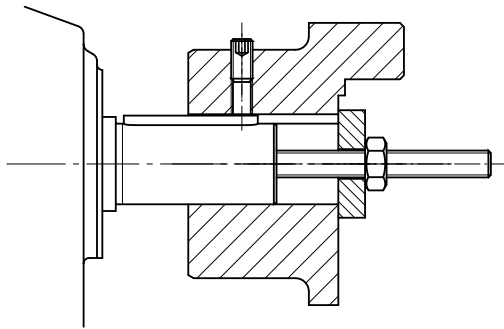

Figure 2: Example of a simple pulling device

During fitting, ensure that the shaft axes are precisely aligned with each other. Comply with the permissible tolerance details provided by the manufacturer.

Information

Use the end thread of the shafts for pulling. Fitting can be facilitated by coating the hub with lubricant or heating it up to approx. 100 °C beforehand.

The maximum radial forces FR1 and FR2 and axial forces FA2 which are imposed on the driving and driven elements of the gear unit must not be exceeded (refer to the name plate). Pay particular attention to the correct tension of belts and chains.

Additional loads due to unbalanced hubs are not permitted.

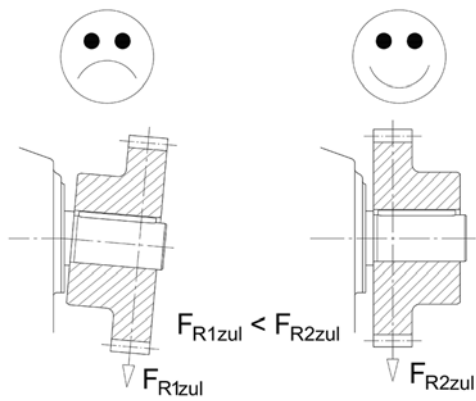

The transverse force must be applied as closely as possible to the gear unit. For drive shafts with free shaft ends (Option W), the maximum permissible transverse force F_{R1} applies for the application of the transverse force to the centre of the free shaft journal. For output shafts, the application of the transverse force F_{R2} must not exceed the dimension x_{R2} . If the radial force F_{R2} is stated on the name plate, but no dimension x_{R2} is stated, application of force is assumed to be to the centre of the shaft journal.

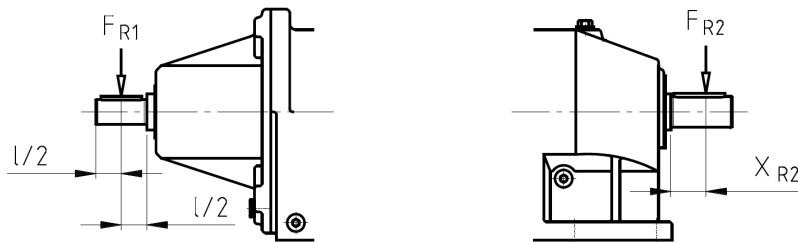

Figure 3: Permissible application of force to drive and driven shafts

3.6 Fitting push-on gear units with fastening element (option: B)

WARNING

Risk of severe injuries

If the screw fastenings of the torque arm are removed during operation, the gear unit will rotate around the output shaft.

- Secure the screw fastening against loosening, e.g. with Loctite 242 or a second nut.

NOTICE

The gear unit may be damaged by axial forces.

Bearings, gearwheels, shafts and housings may be damaged by incorrect fitting.

- Use a suitable pulling device.
- Do not strike the gear unit with a hammer.

Assembly and subsequent dismantling is facilitated by applying an anti-corrosive lubricant to the shaft before fitting (e.g. NORD Anti-Corrosion Part No. 089 00099). Excess lubricant may escape after fitting and may drip off. This escape of grease is not due to a leak in the gear unit. Thoroughly clean these points on the output shaft after a running-in time of approx. 24 hours.

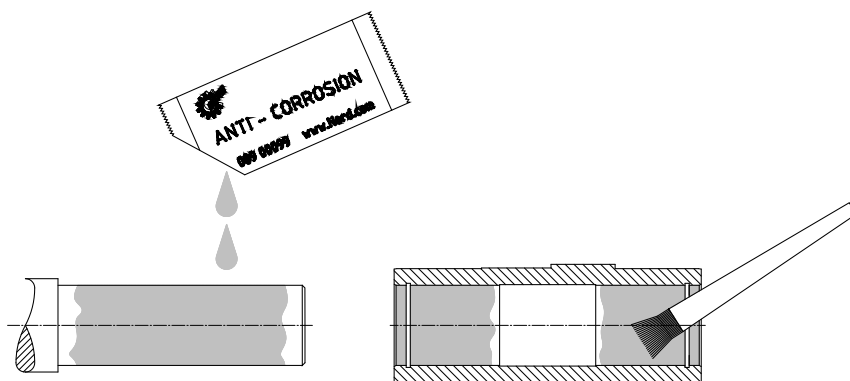

Figure 4: Applying lubricant to the shaft and the hub

For push-on gear units with cover cap IP66 (Option H66) and fastening element (Option B) the pressed-in closing cap must be pushed out before installing the gear unit. The pressed-in closing cap may be destroyed during dismantling. A 2nd closing cap is supplied as a spare part. Fit the closing cap after installation of the gear unit as described in Section 3.9 "Fitting the covers (option: H, H66)".



Figure 5: Removing the factory-fitted closing cap

The gear unit can be fitted to solid shafts with and without a shoulder using the fixing element (Option B). Tighten the fastening element bolt with correct torque (see chapter 7.3 "Screw tightening torques").

When fastening without a contact shoulder, a circlip is used in the hollow shaft for axial fastening.

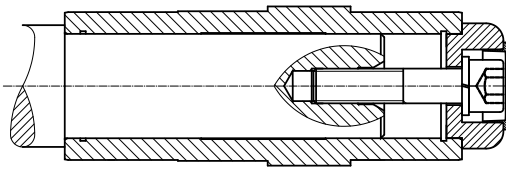

Figure 6: Gear unit mounted on shaft with a shoulder using the fastening element

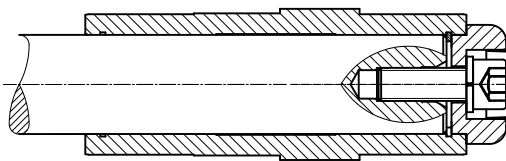

Figure 7: Gear unit mounted on shaft without a shoulder using the fastening element

A gear unit can be removed from a shaft with a shoulder e.g. using the following device.

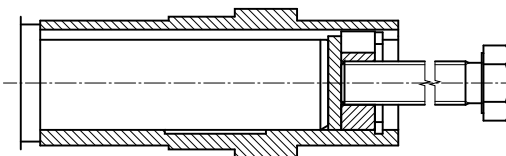

Figure 8: Removal using dismantling device

Do not distort the support when installing push-on gear units with a torque support. Tension-free mounting is aided by the rubber buffer (Option G or VG).

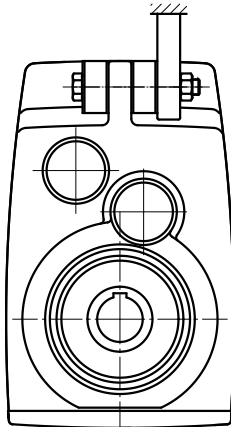
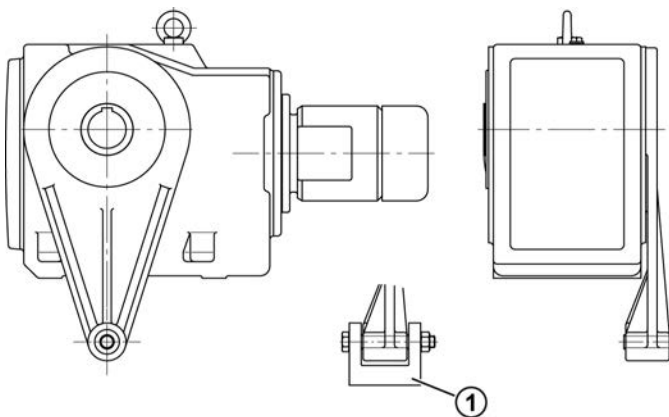

Figure 9: Mounting the rubber buffer (Option G and/or VG) on parallel shaft gear units

To fit the rubber buffer, tighten the screw fastening until there is no play between the contact surfaces when there is no load. For screw fastenings with standard thread, then rotate the fastening nut half a turn in order to pre-tension the rubber buffer. Greater pre-tension is not permissible.



Explanation

- 1 Always support torque support on both sides

Figure 10: Attaching the torque support on bevel gear and worm gear units

Tighten the fastenings of the torque support with the correct torque (see chapter 7.3 "Screw tightening torques") and secure them against loosening, e.g. with Loctite 242 or Loxeal 54-03.

3.7 Fitting a hollow shaft with shrink disc (Option: S)

NOTICE

Risk of damage to the gear unit if the shrink disc is installed incorrectly

- Do not tighten the tensioning bolts if the solid shaft is not installed. This would permanently deform the hollow shaft.

Hollow shafts with shrink discs must be protected from dust, dirt and moisture. NORD recommends option H/H66 (see chapter 3.9 "Fitting the covers (option: H, H66)").

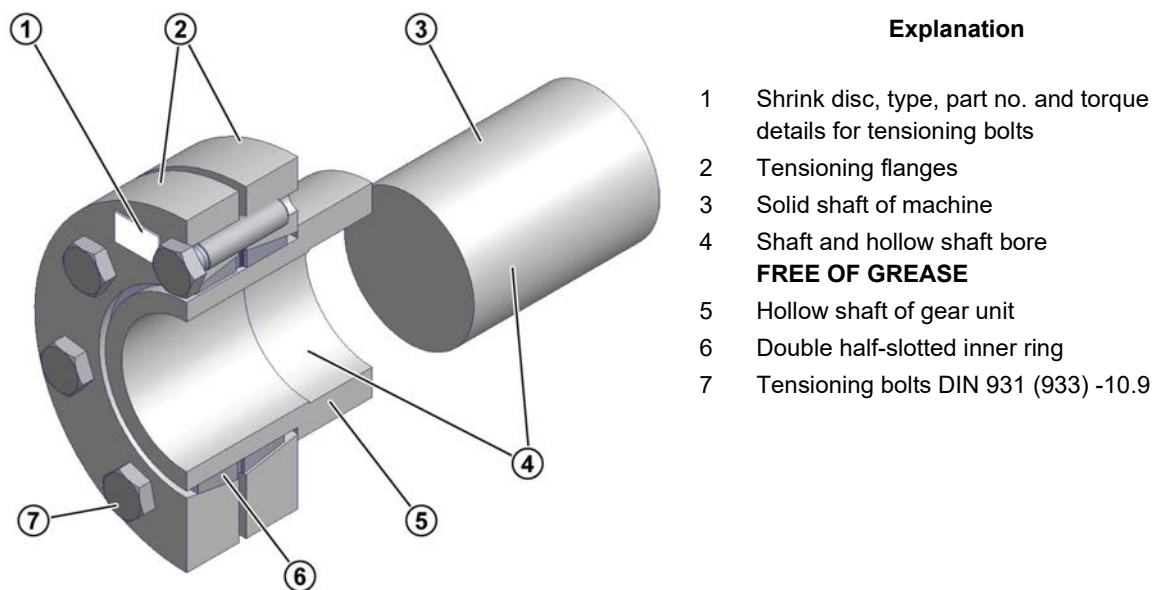

Figure 11: Hollow shaft with shrink disc

The shrink disc is supplied ready for fitting. It must not be dismantled prior to fitting.

The solid shaft material must have a minimum yield strength of 360 N/mm². This ensures that no permanent deformation occurs due to the clamping force.

If necessary, also observe the documentation from the manufacturer of the shrink disc.

Prerequisites

- The hollow shaft must be completely free of grease.
- The solid shaft of the machine must be completely free of grease.
- The external diameter of the solid shaft must be within the tolerance h6 or k6 for highly irregular operation, unless otherwise specified in the order-related dimension sheet. The fit must be according to DIN EN ISO 286-2.

Fitting procedure

1. Remove the cover, if any.
2. Loosen the tensioning bolts of the shrink disc, but do not unscrew them completely. Tighten the tensioning bolts gently by hand until there is no play between the flanges and the inner ring.
3. Lightly grease the bore of the inner ring. Push the shrink disc onto the hollow shaft until the outer clamping flange is flush with the hollow shaft.
4. Grease the solid shaft of the machine in the area which will later come into contact with the bushing in the hollow shaft. Do not grease the bronze bushing. It is essential that the tensioning seat of the hollow shaft is free of grease.
5. Insert the solid shaft of the machine into the hollow shaft so that the area around the shrink connection is completely filled.
6. Tighten the tensioning bolts of the shrink disc with approx. $\frac{1}{4}$ rotation of the bolt per turn **in sequence** in a clockwise direction by several turns.

Use a torque wrench to tighten the tensioning bolts to the tightening torque specified on the shrink disc.
7. Check if there is an even gap between the clamping flanges. If this is not the case, the shrink disc connection must be dismantled and checked for correct fit.
8. Mark the hollow shaft of the gear unit and the solid shaft of the machine with a label in order to detect any slippage under load.

Standard disassembly procedure:

**WARNING**

Danger of injury due to sudden mechanical release

The elements of the shrink disc are under great mechanical tension. Sudden release of the outer rings produces high separating forces and can result in uncontrolled detachment of shrink disc components.

- Do not remove any tensioning bolts if you have not ensured that the external outer rings of the shrink disc have been released from the inner ring.
-

1. Loosen the tensioning bolts of the shrink disc with approx. $\frac{1}{4}$ rotation of the bolt per turn **in sequence** in a clockwise direction by several turns. Do not remove the tensioning bolts from their thread.
2. Loosen the clamping flanges from the cone of the inner ring.
3. Remove the gear unit from the solid shaft of the machine.

If a shrink disc has been in use for a long period or is dirty, dismantle it and clean it before refitting. Check the shrink disc for damage or corrosion. Replace the damaged elements if they are not in perfect condition.

Coat the conical surfaces with MOLYKOTE® G-Rapid Plus or a similar lubricant. Place some multi-purpose grease on the screw thread and the contact surfaces of the screw heads.

3.8 Fitting a hollow shaft with GRIPMAXX™ (Option: M)

NOTICE

Damage to the gear unit due to incorrect installation

- Do not tighten the tensioning bolts of the shrink disc until the solid shaft and the torque bush are in the correct position.

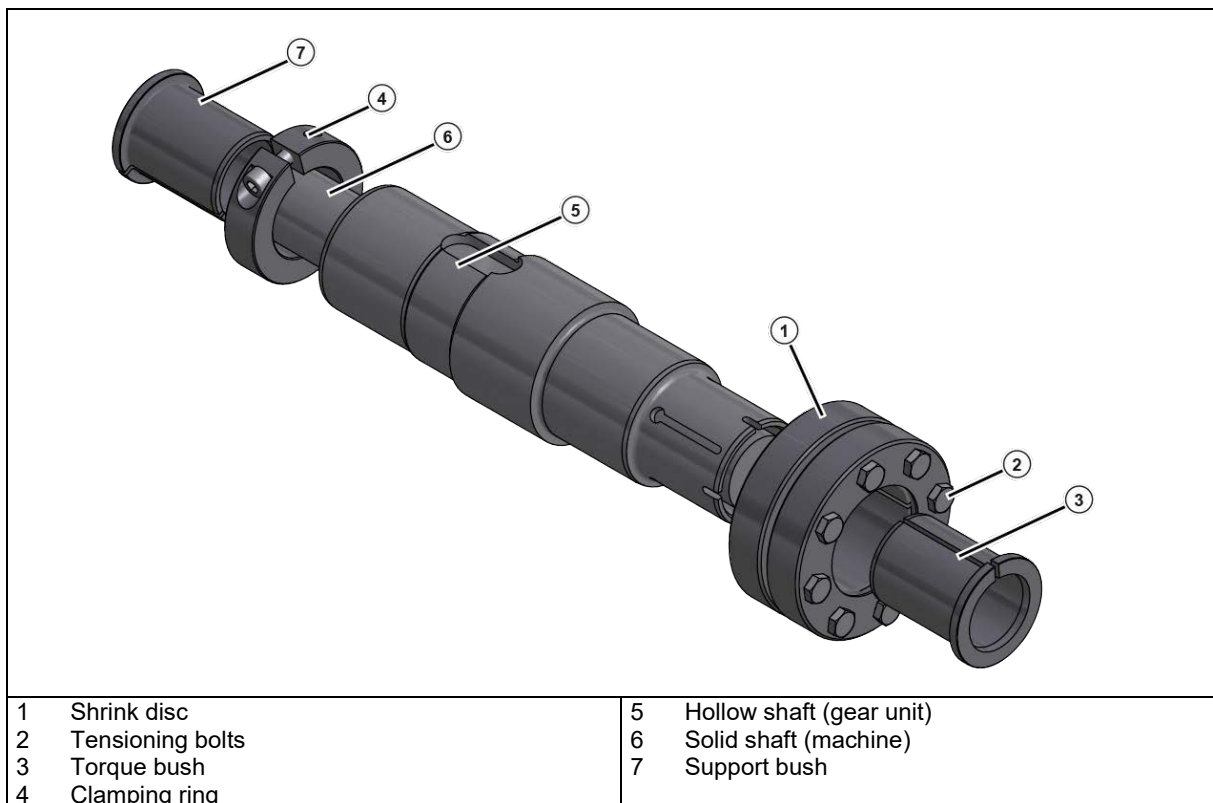

Figure 12: GRIPMAXX™, exploded diagram

Take all expected peak loads into account when dimensioning the solid shaft or the machine shaft.

The solid shaft material must have a minimum yield strength of 360N/mm². This ensures that no permanent deformation occurs due to the clamping force.

Do not use any lubricants, corrosion protection agents, assembly paste or other coatings on the mating surfaces of the shaft, the bushes, the clamping rings or the shrink disc.

Prerequisites

- The solid shaft [6] must be free from burrs, corrosion, lubricants or other foreign bodies.
- The hollow shaft [5], the bushes [3], [7], the clamping ring [4] and the shrink disc [1] must be free from dirt, grease or oil.
- The solid shaft diameter must be within the following tolerances:

Metric machine shafts			Imperial machine shafts		
From	To	ISO 286-2 Tolerance h11(-)	From	To	ISO 286-2 Tolerance h11(-)
Ø [mm]	Ø [mm]	[mm]	Ø [in]	Ø [in]	[in]
10	18	-0.11	0.4375	0.6875	-0.004
18	30	-0.13	0.7500	1.0625	-0.005
30	50	-0.16	1.1250	1.9375	-0.006
50	80	-0.19	2.0000	3.1250	-0.007
80	120	-0.22	3.1875	4.6875	-0.008
120	180	-0.25	4.7500	7.0625	-0.009

Table 4: Permissible machine shaft tolerances

Fitting procedure

1. Determine the correct installation position of the shrink disc [1] on the gear unit. Ensure that the position of the hollow shaft [5] corresponds to the details in the order.
2. Slide the support bush [7] and the clamping ring [4] onto the solid shaft [6]. Ensure that the support bush is correctly positioned. Secure the support bush [7] with the clamping ring [4] by tightening the clamping ring bolt with the appropriate torque (see chapter 7.3 "Screw tightening torques").
3. Push the gear unit onto the secured support bush [7], up to the stop against the clamping ring.
4. Slightly loosen the tensioning bolts [2] and push the shrink disc [1] onto the solid shaft.
5. Push the torque bush [3] onto the solid shaft.
6. Tighten the 3 or 4 tensioning bolts [2] until finger-tight and ensure that the outer rings of the shrink disc are pulled together parallel. Then tighten the remaining bolts.
7. Tighten the tensioning bolts successively in a clockwise direction by several turns – **not crosswise** – with approx. ¼ rotation of the bolt per turn. Use a torque wrench to achieve the tightening torque specified on the shrink disc.

After tightening the tensioning bolts, there must be an even gap between the clamping flanges. If this is not the case, dismantle the shrink disc connection and check the fit.

Dismantling procedure



Danger of injury due to sudden mechanical release

The elements of the shrink disc are under great mechanical tension. Sudden release of the outer rings produces high separating forces and can result in uncontrolled detachment of shrink disc components.

- Do not remove any tensioning bolts if you have not ensured that the external outer rings of the shrink disc have been released from the inner ring.

1. Unscrew the tensioning bolts [2] of the shrink disc in sequence, with approximately half a turn (180°), until the inner ring of the shrink disc can be moved.
2. Pull the shrink disc [1] with the torque bush [3] off from the shaft.
3. Remove the outer rings of the shrink disc from the conical inner ring. For this it may be necessary to lightly tap the bolts with a soft-face hammer or to lightly lever the outer rings apart.
4. Pull the gear unit off the machine shaft.

Clean all individual components before refitting. Check the bushes and the shrink disc for damage or corrosion. Replace the bushes and the shrink disc if they are not in perfect condition. Coat the conical seat of the outer rings and the outside of the clamping ring with MOLYKOTE® G-Rapid Plus or a similar product. Place some multi-purpose grease on the screw thread and the contact surfaces of the screw heads.

3.9 Fitting the covers (option: H, H66)

Use all fastening screws. Secure the fastening screws by coating them with securing lubricant, e.g. Loctite 242, Loxeal 54-03. Tighten the fastening screws with the correct torque (see chapter 7.3 "Screw tightening torques").

For covers with Option H66, press in the new condition closing cap by tapping it lightly with a hammer.

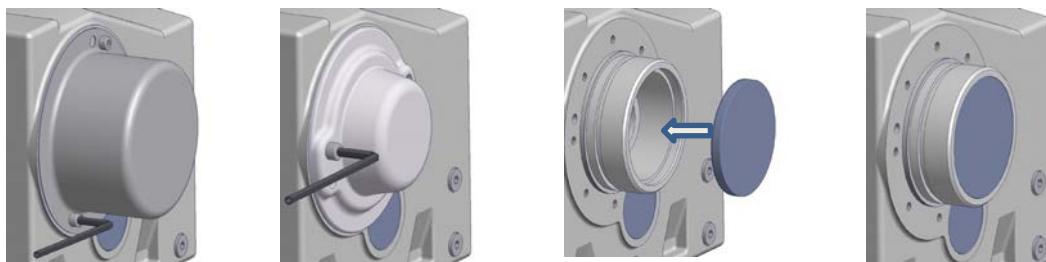

Figure 13: Fitting the covers, Option SH, Option H, and Option H66

3.10 Fitting the covers

Some versions of universal worm gear units are delivered as standard with a plastic cover cap. The cover cap protects the radial shaft seals against the entry of dust and other contamination. The cover cap can be attached on the A side or the B side. It can be removed by hand without tools.

NOTICE

Damage to the expansion elements of the cover cap

- Do not jam the cover cap when pulling it off or attaching it.

Pull the cover cap off vertically prior to the installation of the universal worm gear unit. After completing the fitting, attach the cover cap onto the right side by attaching the expanding elements into the threaded holes on the output flange.



Figure 14: Disassembly and assembly of the cover cap

3.11 Fitting a standard motor (Option: IEC, NEMA, AI, AN)

Depending on the gear unit type, exceptions are permissible with the maximum motor weights. These are indicated in the tables below and must not be exceeded.

Maximum permitted motor weights														
Motor size	63	71	80	90	100	112	132	160	180	200	225	250	280	315
Max. motor weight [kg]	25	30	50	50	80	80	100	250	250	350	500	1000	1000	1500
SK 32, SK 3282, SK 9032.1, SK 32100, SK 772.1, SK 773.1					100	100								
SK 42, SK 4282, SK 9042.1, SK 42125					100	100	130	200						
SK 52, SK 63, SK 5282, SK 6382, SK 9052.1, SK 872.1, SK 873.1, SK 972.1, SK 973.1					100	100	130							
SK 62, SK 73, SK 83, SK 6282, SK 7382, SK 8382, SK 9072.1					100	100	130							
SK 72, SK 82, SK 93, SK 103, SK 7282, SK 8282, SK 9382, SK 10382.1, SK 9082.1, SK 9086.1, SK 9092.1, SK 9096.1							130							
SK 920072.1, SK 92072.1, SK 0, SK 071.1, SK 0182.1, SK 930072.1, SK 93072.1, SK 93372.1			40											
SK 1382NB, SK 1382.1, SK 92372, SK 92372.1, SK 12063, SK 372.1, SK 371.1, SK 1382.1 GJL					60									
SK 971.1										250 ¹				
SK 1091.1											350 ²			

1 In mounting positions M2, M4, M6: 350 kg, otherwise, as indicated.

2 In mounting positions M1, M2, M4, M5, M6: 500 kg, otherwise, as indicated.

Table 5: Motor weights IEC motors

Maximum permitted motor weights														
Motor size		56C		140TC		180TC	210TC	250TC	280TC	320TC	360TC	400TC		
Max. motor weight [kg]		30		50		80	100	200	250	350	700	700		
SK 62, SK 72, SK 73, SK 83, SK 93, SK 9072.1, SK 6282, SK 7282, SK 7382, SK 8382, SK 9382											500	500		

Table 6: Motor weights NEMA motors

Fitting a standard motor to the IEC adapter (Option IEC) or NEMA adapter (Option NEMA)

1. Clean the motor shaft and the flange surfaces of the motor and motor adapter, and check them for damage. Check the motor dimensions. The dimensions must be within the tolerances according to DIN EN 50347 or NEMA MG1 Part 4.
2. For motor sizes 90, 160, 180 and 225, position the spacer bushes that may be provided onto the motor shaft.
3. Position the half-coupling onto the motor shaft so that the motor parallel key engages into the groove of the half-coupling. Tighten the half-coupling in accordance with the motor manufacturer's instructions. With standard helical gear units, observe dimension B between the half-coupling and the collar (see "Figure 15"). Adjust the coupling in accordance with the specifications indicated on the adhesive plate for certain **NEMA adapters** .
4. If the half-coupling contains a setscrew, secure the coupling axially on the shaft. Coat the setscrew with securing adhesive before screwing it in, e.g. Loctite 242 or Loxeal 54-03, and tighten it with the correct torque (see chapter 7.3 "Screw tightening torques").
5. Sealing of the flange surfaces is recommended if the motor is installed outside or in a humid environment. Completely coat the flange surfaces with surface sealant, e.g. Loctite 574 or Loxeal 58-14.
6. Attach the motor to the adapter. Also attach the enclosed ring gear or the enclosed gear sleeve (see figure below).
7. Tighten the adapter bolts with the correct torque (see chapter 7.3 "Screw tightening torques").

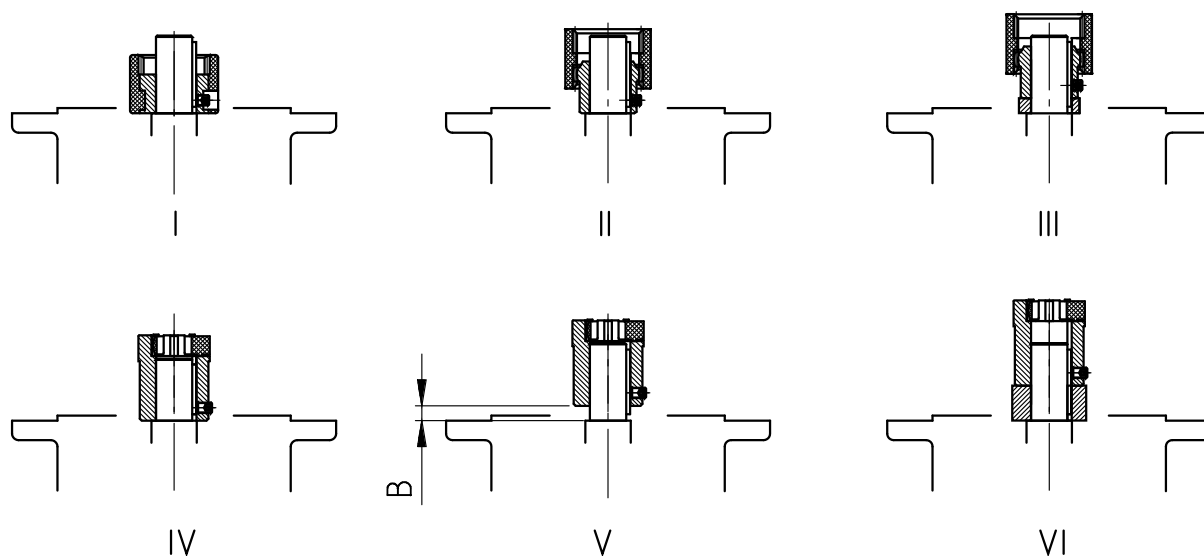

Figure 15: Fitting the coupling onto the motor shaft - various types of coupling

- I Curved tooth coupling (BoWex®), one-piece
- II Curved tooth coupling (BoWex®), two-piece
- III Curved tooth coupling (BoWex®), two-part with spacer bush
- IV Claw coupling (ROTEX®), two-piece
- V Claw coupling (ROTEX®), two-piece, observe dimension B:

Standard helical gear units:		
SK 0, SK 01, SK 20, SK 25, SK 30, SK 33 (2-stage)		
SK 010, SK 200, SK 250, SK 300, SK 330 (3-stage)		
	IEC size 63	IEC size 71
Dimension B (Fig. V)	B = 4.5 mm	B = 11.5 mm

- VI Claw coupling (ROTEX®), two-piece with spacer bush

Fitting a standard motor to the IEC adapters AI160–AI315 (Option AI) or NEMA adapters AN250TC–AN400TC (Option AN)

1. Clean the motor shaft and the flange surfaces of the motor and motor adapter, and check them for damage. Check the motor dimensions. The dimensions must be within the tolerances according to DIN EN 50347 or NEMA MG1 Part 4.
2. Remove the motor shaft's key.

Note: For adapter AI315, the key does not have to be dismantled. Continue with Step 5. of this description.
3. With the adapters AI160, AI180 and AI225, attach the spacer bush supplied with the product.
4. Attach the key supplied with the product (see "Table7: Motor parallel keys").
5. For the attachment of the half-coupling, heat up the half-coupling to approx. 100 °C. Position the half-coupling as follows:
 - Push AI160, AI180 and AI225 on to the spacer bush.
 - Push AI200, AI250, AI280 and AI315 on to the motor shaft collar.
 - AN250TC–AN400TC until dimension A has been attained (see "Table 8: Position of the half-coupling on the NEMA motor shaft")

6. If the half-coupling contains a setscrew, secure the coupling axially on the shaft. Coat the setscrew with securing adhesive before screwing it in, e.g. Loctite 242 or Loxeal 54-03, and tighten it with the correct torque (see chapter 7.3 "Screw tightening torques").
7. Sealing of the flange surfaces is recommended if the motor is installed outside or in a humid environment. Completely coat the flange surfaces with surface sealant, e.g. Loctite 574 or Loxeal 58-14.
8. Attach the motor to the adapter. Also attach the enclosed ring gear or the enclosed gear sleeve (see **Figure 15: Fitting the coupling onto the motor shaft - various types of coupling**). For the AN360TC and AN400TC adapters, attach the adapter flange to the motor first, and screw the motor onto the adapter.
9. Tighten the adapter bolts with the correct torque (see chapter 7.3 "Screw tightening torques").

IEC/NEMA type	Coupling	Shaft ϕ	Motor shaft's key
AI 160	R42	42	AB12x8x45
AI 180	R48	48	AB14x9x45
AN 250	R42	41.275	B3/8x3/8x1 1/2
AN 280	R48	47.625	B1/2x1/2x1 1/2
AI 200	R55	55	B16x10x50x
AN 320	R55	53.976	B1/2x1/2x1 1/2
AI 225	R65	60	B18x11x70
AN 360 R350	R65	60.325	B5/8x5/8x2 1/4
AI 250	R75	65	B18x11x70
AI 280	R75	75	B20x12x70
AN 360 R450	R75	60.325	B5/8x5/8x3 1/8
AN 400	R75	73.025	B3/4x3/4x3 1/4

Table7: Motor parallel keys

	NEMA type	Coupling size	A [mm]
	N250TC R350	R42	83
	N250TC 300S	R42	86
	N280TC R350	R48	87.5
	N280TC 300S	R48	102.5
	N320TC	R55	91
	N360TC/350	R65	126.5
	N360TC/450	R75	150.5
	N400TC	R75	164.5

Table 8: Position of the half-coupling on the NEMA motor shaft

3.12 Mounting of the cooling coil onto the cooling system

⚠ WARNING

Risk of injury due to pressure discharge

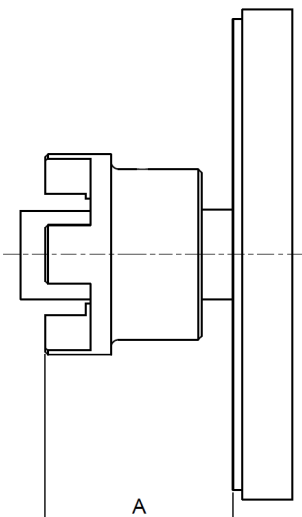
- Ensure that the pressure is released from the cooling circuit before carrying out any work on the gear unit.

NOTICE

Damage to the cooling coil

- Do not twist the connection pieces during installation.
- Ensure load-free assembly of the connection pipes or hoses.
- Even after the installation, no external forces must be able to act on the cooling coil via the connection pieces.
- Prevent vibrations from reaching the cooling coil during operation.

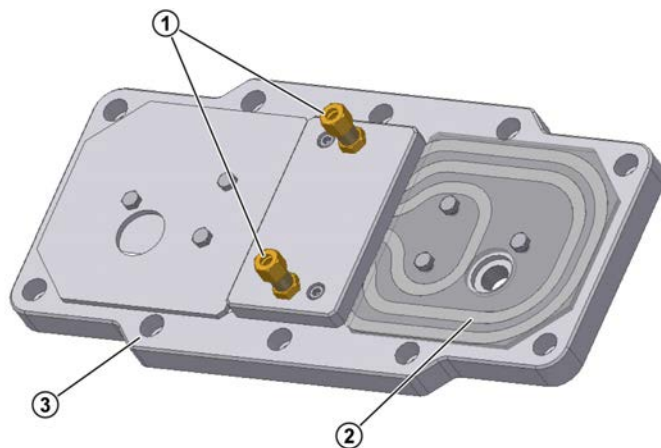

Explanation

- | | |
|---|---|
| 1 | Connection pieces with cutting ring screw connections |
| 2 | Cooling coil |
| 3 | Housing cover |

Figure 16: Cooling cover

The cooling coil is installed in the housing cover. For the inlet and outlet of cooling fluid, connection pieces with cutting ring screw connections according to DIN 2553 are provided on the housing cover for a connection of a pipe with an external diameter of 10 mm.

Remove the sealing plug from the screw necks prior to assembly and flush the cooling coil to prevent any contamination of the cooling system. Then, connect the connection pieces with the coolant circuit. The flow direction of the coolant is irrelevant.

3.13 Installation of the external oil/air cooler

i Information

Installation information

To ensure optimal air supply, the distance between the cooling unit and the wall should be at least 600 mm.

3.13.1 Connecting hose lines

NOTICE

Gear unit is supplied without oil filling

- Fill the gear unit with oil before commissioning.

The scope of delivery includes the oil/air cooler and the necessary hose lines.

Connect the oil/air cooler according to the illustration. Make sure that the oil/air cooler has not been mounted above the gear unit.

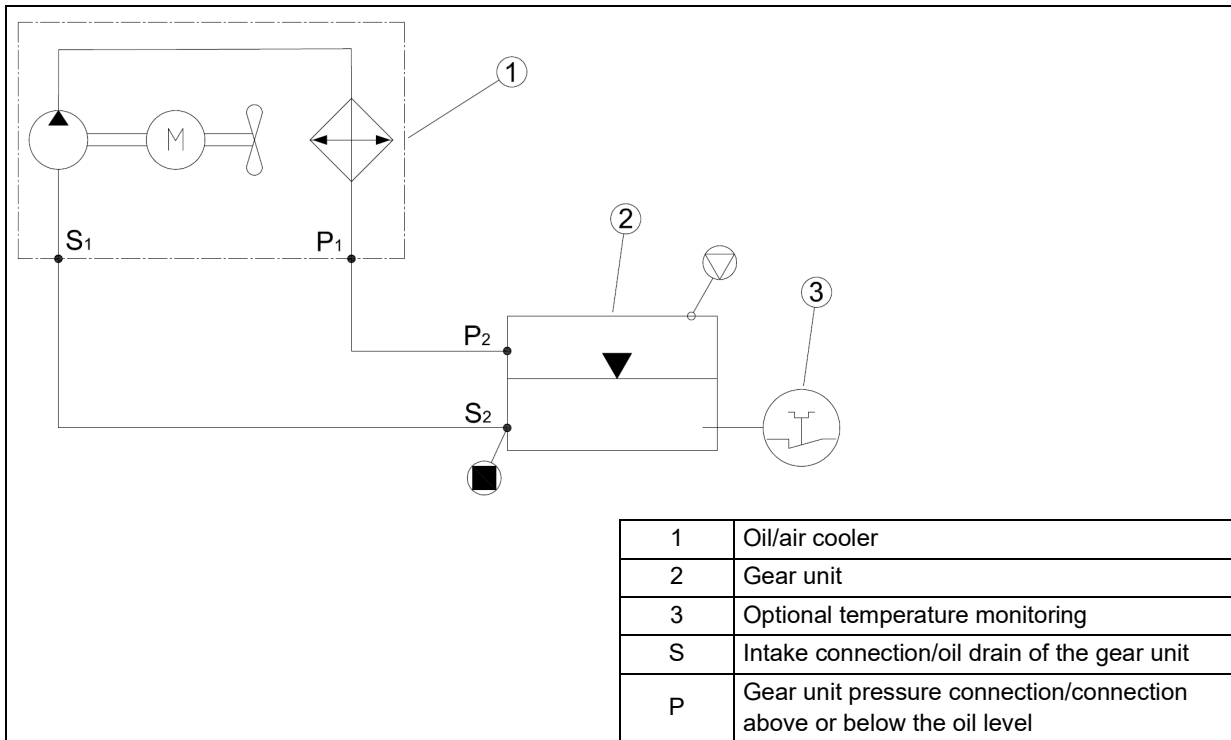

Figure 17: Connection of the oil/air cooler

Fasten the union nuts according to 7.3 "Screw tightening torques".

After assembling the oil lines, fill the gear unit housing with the gear oil type that is printed on the name plate. The oil quantity on the name plate is a guide value and may vary depending on the gear ratio. Approximately 4.5 l of oil are additionally required for the hose lines. When filling, use the oil level screw as an indicator for the correct oil level.

3.13.2 Electrical connection

Ensure the electrical connection according to the operating and installation instructions of the oil/air cooler. Make sure that the direction of rotation of the motor or the fan wheel matches the information provided by the manufacturer of the cooling unit.

3.14 Installation of an oil expansion chamber (Option: OA)

3.14.1 Installation of the sizes I, II and III

The oil expansion chamber is available in 3 sizes with different capacities:

- 0.7 l (size I)
- 2.7 l (size II)
- 5.4 l (size III)

The oil expansion chamber must be mounted vertically with the hose connection facing downwards and the vent screw facing upwards. Taking the hose length into account, the container should be fitted as high as possible. For suggestions for the position of the oil expansion chamber, see the following illustration.

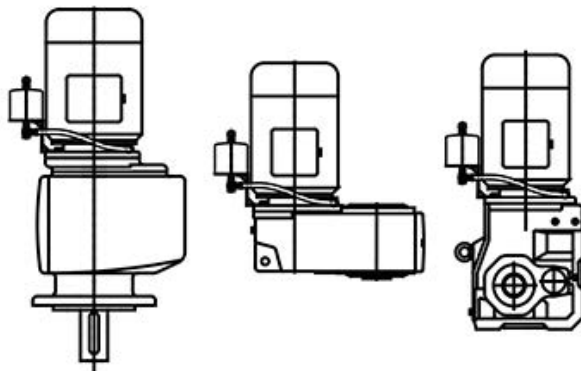

Figure 18: Position of the oil expansion chamber

1. After installing the gear unit, remove the top screw plug.
2. Screw in the reduction or extension with the existing sealing ring.

For gear units having an oil maintenance bore with an M10x1 thread, also consider document WN 0-521 35.

3. If the fastening screw is screwed into a through hole, seal the thread with a medium-strength screw-securing material such as LOXEAL 54-03 or Loctite 242.
4. Screw on the expansion tank. If the necessary screw insertion depth of $1.5 \times d$ can no longer be achieved, use a 5 mm longer screw. If a longer screw cannot be fitted, use a stud and a nut with appropriate dimensions.
5. Attach the vent hose with the enclosed hollow screws and seals.
6. Screw the enclosed M12 x 1.5 vent plug and sealing ring into the tank.

3.14.2 Installation of sizes 0A and 0B

The oil expansion chamber must be mounted vertically with the connection pipe facing downwards and the vent screw facing upwards. Install the container as high as possible. Suggestions for the position of the oil expansion chamber see Figure 18. Note that with the M4 configuration with terminal box position in position 2, the installation of the oil expansion chamber is not possible.

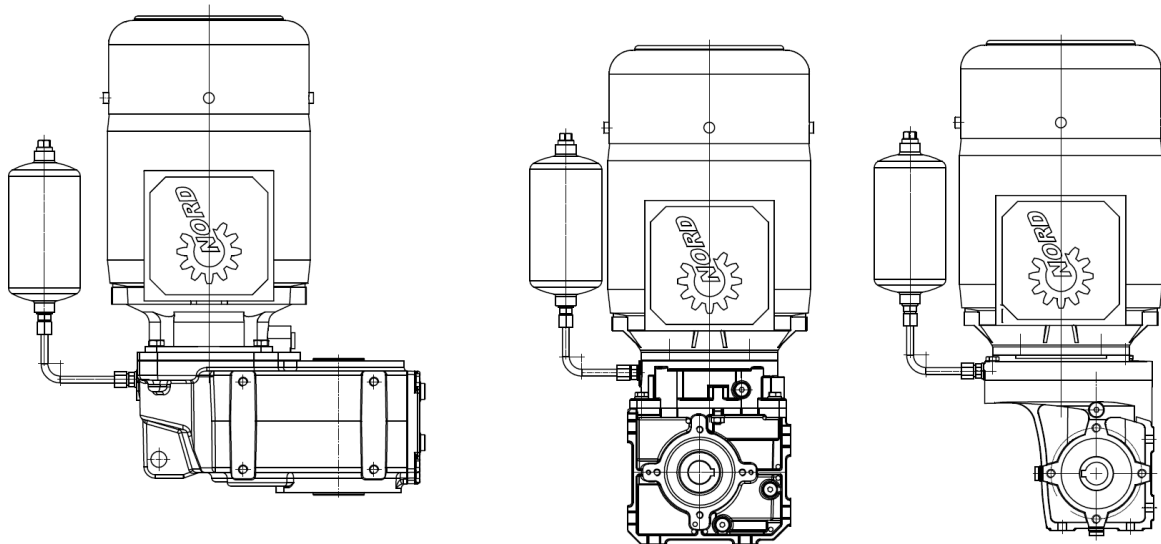

Figure 19: Position of the oil expansion chamber

1. After installing the gear unit, remove the oil level screw or the top screw plug.
2. Install the oil expansion chamber according to Figure 18. Align it parallel to the motor shaft.
3. Maintain the maximum tightening torque of 12 Nm for screwing the oil expansion chamber onto the gear unit housing.

3.15 Subsequent painting

For retrospective painting of the gear unit, the shaft sealing rings, rubber elements, pressure vent screws, hoses, type plates, adhesive labels and motor coupling components must not come into contact with paints, lacquers or solvents, as otherwise the components may be damaged or made illegible.

3.16 Electrical connection of the mounted motor

For geared motors (gear units with attached electric motor), the electric motor has its own operating instructions. If these operating instructions are not available, please request them from the motor manufacturer. Ensure the electrical connection of the motor in accordance with the operating instructions of the motor. Usually, there is a connection diagram in the terminal box of the motor.

4 Commissioning

4.1 Checking the oil level

Check the oil level before commissioning (see chapter 5.2 "Service and maintenance work").

4.2 Activating the vent

If venting of the gear unit is provided, the vent or the pressure vent must be activated before commissioning. Double gear units consist of two single units, are equipped with 2 oil chambers and possibly 2 vents.

To activate, remove the sealing cord in the vent screw. For the vent screw position, see Section 7.1 "Versions and mounting position".

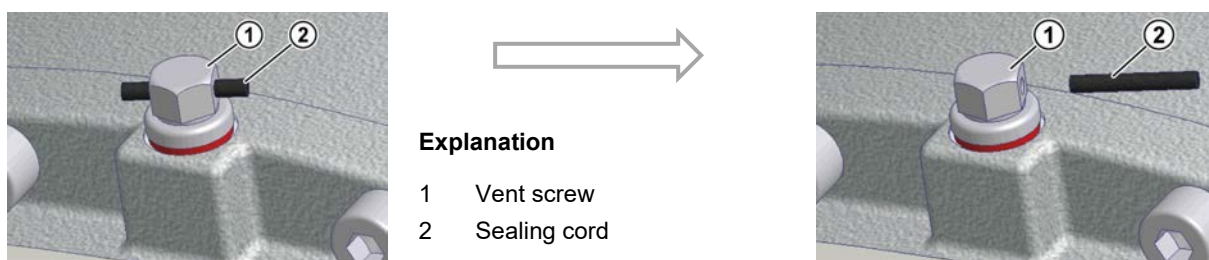

Figure 20: Activating the vent screw

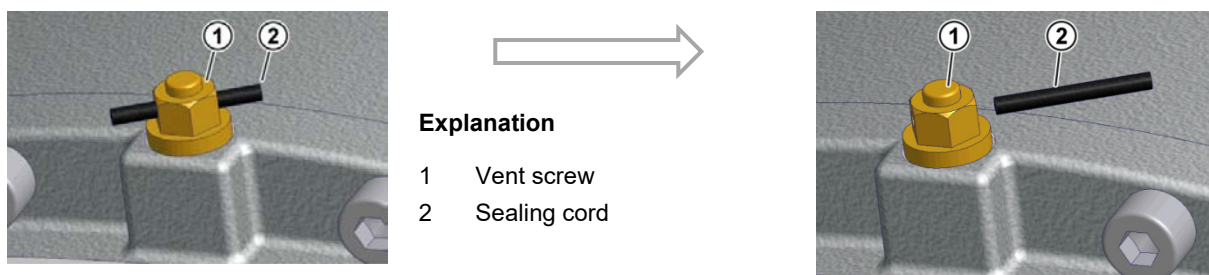
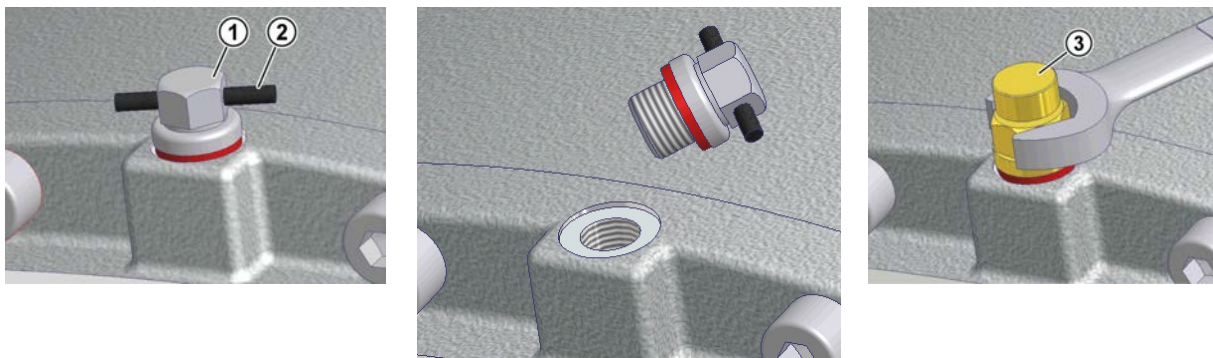

Figure 21: Activating the pressure vent screw

Special pressure vents are supplied as loose parts. Unscrew the vent screw and replace it with the special pressure vent and seal.



Explanation

- | | | |
|------------|--------------|--------------------|
| 1 | 2 | 3 |
| Vent screw | Sealing cord | Special vent screw |

Figure 22: Removing the vent plug and fitting the special pressure vent

4.3 Activating the automatic lubricant dispenser

Some gear unit types with standard motor (Option IEC/NEMA, not AI/AN) have an automatic lubricant dispenser for the roller bearings. The lubricant sensor must be activated prior to commissioning the gear unit. The cartridge case cover of the adapter for attaching an IEC/NEMA standard motor has a red information sign for activation of the lubricant dispenser. Opposite to the lubricant dispenser there is a grease escape hole which is closed with a G1/4 cap screw. After activation of the lubricant dispenser, the cap screw can be removed and replaced with the grease collection container (Part No. 28301210) which is supplied separately with the delivery.

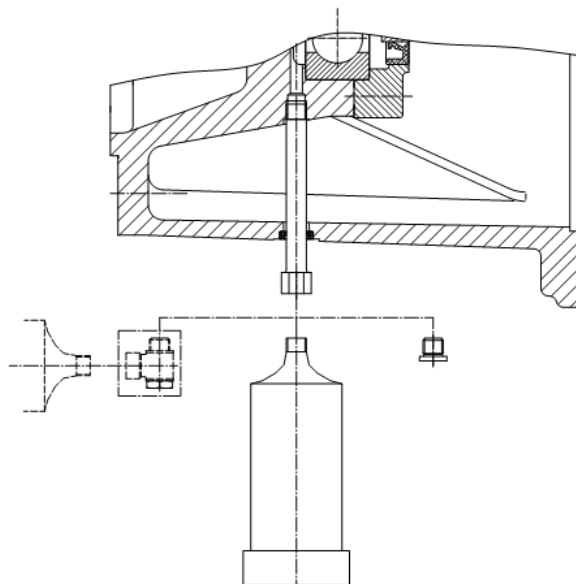
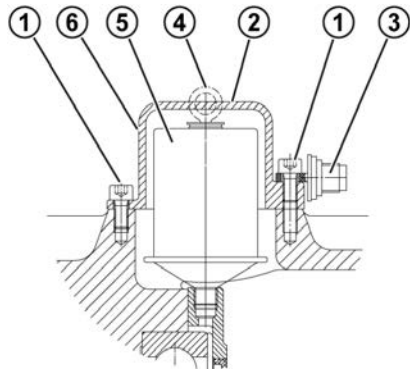

Figure 23: Fitting the grease collection container

Procedure:

1. Loosen and remove the cap screws.
2. Remove the cartridge cover.

3. Screw the activation screw into the lubricant dispenser until the lug breaks off at the defined fracture point.
4. Re-fit the cartridge cover. Attach the cartridge cover with the cap screws (see chapter 7.3 "Screw tightening torques").
5. Mark month and year of activation on the adhesive label.



Explanation

- | | |
|---|----------------------------|
| 1 | Cap screws M8 x 16 |
| 2 | Cartridge cover |
| 3 | Activation screw |
| 4 | Lug |
| 5 | Lubricant sensor |
| 6 | Position of adhesive label |

Figure 24: Activating the automatic lubricant sensor with standard motor mounting

Adhesive label

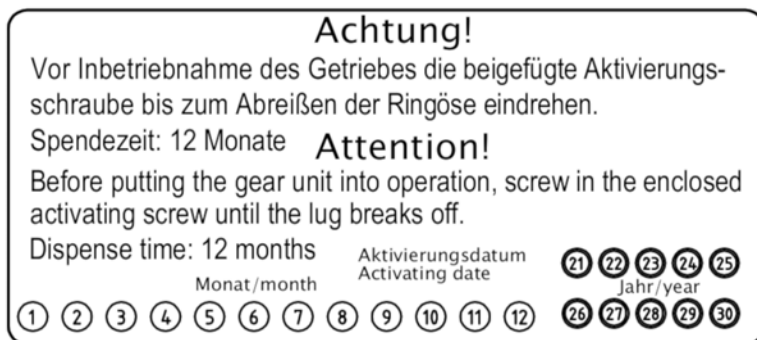

Figure 25: Adhesive label

4.4 Cooling coil (Option: CC)

NOTICE

Gear unit damage due to overheating

- Only start up the drive after the cooling coil has been connected to the cooling circuit, and the cooling circuit has been put into operation.

If there is a danger of frost, a suitable anti-freeze solution must be added to the cooling water in due time.

The coolant must have a thermal capacity similar to water.

- Specific thermal capacity of water at 20 °C: $c = 4.18 \text{ kJ/kgK}$

Clean, industrial water without any air bubbles or sediments is recommended as a coolant. The hardness of the water must be between 1 dH and 15 dH; the pH value must be between pH 7.4 and pH 9.5. No aggressive liquids may be added to the coolant!

The **coolant pressure** must not exceed **8 bar**. We also recommend fitting a pressure reducer at the coolant inlet to avoid damage due to excessive pressure.

The **coolant inlet temperature** must not exceed 40 °C. **10 °C** are recommended.

The required **coolant flow rate** is **10 l/min**.

The temperature and the flow rate of the cooling fluid must be monitored and ensured. The drive must be shut down if the permissible temperature is exceeded.

4.5 External oil/air cooler

NOTICE

Gear unit damage due to overheating

- Only start up the drive after the external oil/air cooler has been connected and put into operation.

NOTICE

Damage due to high line pressure

- In case of cold starting, ensure that the maximum permissible viscosity of the lubricant is not exceeded, in order to prevent excess pressure in the pump and the lubrication lines.

Main components of the external oil/air cooler:

- Motor
- Pump
- Heat exchanger

After mounting and filling the oil/air cooler, check the oil level in the gear unit. Make sure that the oil/air cooler is vented.

For basic information on the available versions of the oil/air cooler, refer to our G1000 catalogue (see www.nord.com).

For detailed information on the external oil/air cooler, refer to the relevant operating instructions. The information contained therein takes precedence.

Unless otherwise indicated by the manufacturer of the external oil/air cooler, the following applies to it:

- Minimum line pressure on the suction side: -0.4 bar
- Maximum viscosity of the lubricant: 1000 mm²/s

Select a motor speed on the coil/air cooler, which ensures complete filling of the pump. This can be achieved by not falling below the minimum line pressure on the suction side.



Information

Gear oil temperature regulation

It is recommended to only switch on the cooling unit at an oil temperature above 60 °C and to switch it off at an oil temperature below 45 °C. For this purpose, temperature regulation can be optionally provided by means of a thermistor (PT100), which has been installed in the oil sump of the gear unit.

The maximum permissible gear oil temperature must not exceed +90 °C.

4.6 Running-in time for the worm gear unit

In order to achieve maximum efficiency of the worm gear unit, the gear unit must be subjected to a running-in period of approx. 25 h – 48 h under maximum load.

There may be a reduction in efficiency before the running-in period is complete.

4.7 AI/AN adapter operation with option BRG1

In connection with option BRG1 (manual re-lubrication), the IEC adapters (option: AI) or the NEMA adapters (option: AN) may be operated at a maximum input speed of 1800 min⁻¹. Higher speeds would lead to premature failure of the seals and coupling spider.

4.8 Checklist

Checklist		
Subject of check	Date of check:	Information see Section
Is the vent screw activated or the pressure vent screwed in?		4.2
Does the required mounting position comply with the actual position?		7.1
Are the external gear shaft forces within permitted limits (chain tension)?		3.5
Is the torque arm installed correctly?		3.6
Are rotating parts covered with a contact guard?		3.9
Is the automatic lubricant sensor activated?		4.3
Is the cooling system connected?		3.12 3.13

Table 9: Checklist for commissioning

5 Service and maintenance

5.1 Inspection and maintenance intervals

Inspection and maintenance intervals	Inspection and maintenance work	Information, see Section
At least every six months	<ul style="list-style-type: none"> • Visual inspection • Check for running noises • Oil level check • Visual inspection of hose • Re-grease/remove excess grease (only applicable for free input shaft/option W, for agitator bearings/option VL2/VL3 and for AI.../AN... adapters with option BRG1) • Replace the automatic lubricant sensor/remove excess grease (for IEC/NEMA standard motor installations, an interval of one year for the replacement of the lubricant sensor is permissible for running times of < 8 h/day); drain or replace the lubricant collection container at each second replacement of the lubricant sensor 	5.2.1 5.2.2 5.2.3 5.2.5 5.2.6 5.2.7
For operating temperatures up to 80 °C Every 10,000 operating hours, at least every 2 years	• Change the oil (if filled with synthetic products, the interval is doubled; with the use of SmartOilChange , the interval is specified by SmartOilChange)	5.2.8
	• Clean or replace the vent screw as necessary	5.2.9
	• Replacing the radial shaft seals; see Chapter 5.2.1 for further information	5.2.10
Every 20,000 operating hours, at least every 4 years	• Re-lubricate the bearings in the gear unit	5.2.11
At least every 10 years	• General overhaul	5.2.12

Table 10: Inspection and maintenance intervals

Information

The oil change intervals apply for normal operating conditions and operating temperatures up to 80 °C. The oil change intervals are reduced in the case of extreme operating conditions (operating temperatures higher than 80 °C, high humidity, aggressive environment and frequent fluctuations in the operating temperature).

Information

SmartOilChange determines the optimum time for an oil change based on a continuous determination of the oil temperature. With **SmartOilChange** from Getriebebau NORD, this is achieved entirely on the basis of product-specific key data, the specified ambient temperature and internal measurement values of the power electronics such as the current consumption. Additional hardware is therefore not required for the Getriebebau NORD solution.

The measurement results are processed and interpreted by the integrated software and result in the display of the calculated residual time until the next oil change.

5.2 Service and maintenance work

5.2.1 Visual inspection for leaks

The gear unit must be checked for leaks. Attention should be paid to escaping gear oil and traces of oil on the exterior or underneath the gear unit. In particular, the radial shaft seals, cover caps, screw fittings, hoses and housing joints should be checked.

Information

Radial shaft seals are components with a limited life and are subject to wear and ageing. The service life of radial shaft seals depends on various ambient conditions. Temperature, light (especially UV light), ozone and other gases and liquids affect the ageing process of radial shaft seals. Some of these influences may change the physical or chemical properties of the radial shaft seals and result in a significant reduction of their service life. Foreign matter (e.g. dust, sludge, sand, metallic particles) and excess temperature (excessive speed or external heating) accelerate the wear of the sealing lip. These sealing lips are made of an elastomer material and are lubricated with a special grease at the factory. This reduces the wear due to their function and ensures a long service life. An oil film in the region of the rubbing sealing lip is therefore normal and is not due to leakage (see chapter 7.5 "Leakage and leak-tightness").

The following applies to radial shaft seals on gear unit output shafts: "Under moderate operating conditions (up to 80 °C oil temperature), the manufacturers of radial shaft seals state non-binding typical lifetimes of up to 10,000 operating hours."

NOTICE

Damage to the radial shaft seals through unsuitable cleaning agents

Unsuitable cleaning agents may damage the radial shaft seals, which may then cause an increased risk of leaks.

- Do not clean the gear unit with cleaning agents which contain acetone or benzol.
 - Avoid contact with hydraulic oils.
-

If leaks are suspected, the gear unit should be cleaned, the oil level checked and checked again for leaks after approx. 24 hours. If a leak is confirmed (dripped oil), the gear unit must be repaired immediately. Please contact the NORD service department.

If the gear unit is equipped with a cooling coil in the housing cover, the connections and the cooling coil must be checked for leaks. If there are any leaks, these must be repaired immediately. Please contact the NORD service department.

5.2.2 Check for running noises

If the gear unit produces unusual running noises or vibrations, this could indicate damage to the gear unit. In this case the gear unit must be repaired immediately. Please contact the NORD Service department.

5.2.3 Checking the oil level

Section 7.1 "Versions and mounting position" describes the mounting positions and the corresponding oil level screws. With double gear units, the oil level must be checked on both units. The pressure vent must be at the position marked in Section 7.1 "Versions and mounting position".

The oil level does not need to be checked on gear units without oil level screw (see chapter 7.1 "Versions and mounting position").

Gear unit types that are not supplied with an oil filling must be filled before the oil level is checked.

The oil level must only be carried out when the gear unit is at a standstill and has cooled down. Provide protection against accidental activation. Check the oil level with an oil temperature of between 10 °C to 40 °C.

Gear units with oil level screw

1. Unscrew the oil level screw corresponding to the mounting position (see chapter 7.1 "Versions and mounting position").

Information

At the first oil level check a small amount of oil may escape, as the oil level may be above the lower edge of the oil level hole.

2. The correct oil level is at the lower edge of the oil level hole. If the oil level is too low, adjust the oil level with the corresponding oil type.
3. Screw the oil level screw and all previously loosened screw connectors back in correctly.

Gear units with an oil level tank

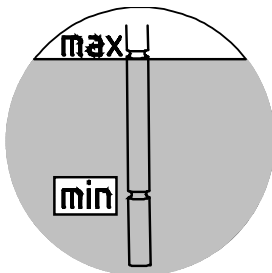

Figure 26: Checking the oil level with a dipstick

1. Screw the screw plug with dipstick (thread G1¼) out of the oil level container.
2. The oil level must be between the upper and lower marking when the dipstick is fully screwed in (see Figure 26). If the oil level is too low, adjust the oil level with the corresponding oil type.
3. Screw the screw plug with dipstick and all previously loosened screw connectors back in correctly.

Gear units with oil inspection glass

1. The oil level can be seen directly in the window.
2. The correct oil level is:
 - Maximum: the middle of the oil inspection glass,
 - Minimum: Lower edge of the oil inspection glass.
3. If the oil level is not correct, adjust the oil level by draining off oil or topping up with the type of oil stated on the name plate.

5.2.4 Visual inspection of the rubber buffers (Option: G, VG)

If these show damage such as tears to the surface, the rubber elements must be replaced. In this case, please contact NORD Service.

5.2.5 Visual inspection of the hoses (Option: OT, CS2-X)

Gear units with an oil tank and external cooling units have rubber hoses.

Check the hoses and screw connectors for leaks, cuts, tears, porous areas and chafing. In case of damage, the hoses must be replaced. Please contact the NORD service department.

5.2.6 Re-greasing (Option: VL2, VL3, W, AI, AN)

Some gear unit designs are equipped with a re-greasing device.

For the agitator versions VL2 and VL3, unscrew the vent screw opposite the grease nipple prior to re-greasing. Inject grease until a quantity of 20 - 25g escapes from the vent hole. Screw the vent screw back in.

For option W and the IEC/NEMA adapters AI and AN with option BRG1, grease the outer roller bearing with approx. 20–25 g of grease at the grease nipple. With the IEC/NEMA adapters AI and AN, the grease nipple is located under a bolt-on inspection cover. Before re-greasing, unscrew the grease drain screw so that the excess grease can drain off. Remove the excess grease on the motor adapter.

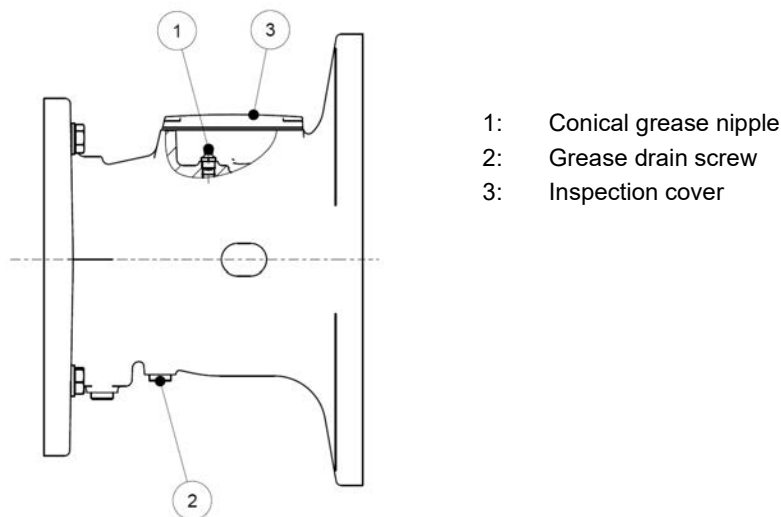

Figure 27: Re-grease IEC/NEMA adapters AI and AN with option BRG1

Recommended grease:

- Petamo GHY 133N (Klüber Lubrication)

5.2.7 Replacing the automatic lubricant dispenser

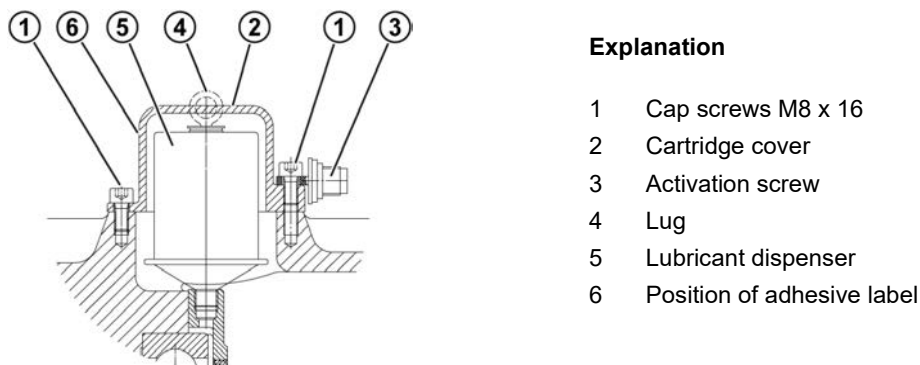

Figure 28: Switching the automatic lubricant sensor with standard motor mounting

(Lubricant sensor: Part No.: 28301000 or for food-compatible grease Part No.: 28301010)

1. Unscrew the cartridge cover.
2. Unscrew the lubricant sensor.
3. Screw in the new lubricant sensor.
4. Remove excess grease from the adapter.
5. Activate the full lubricant sensor (see chapter 4.3 "Activating the automatic lubricant dispenser").

The grease collection container (Part No. 28301210) must be replaced or drained with every second replacement of the lubricant sensor. Due to the form of the container, a residual amount of grease remains in the container.

1. Unscrew the grease collection container from the screw connector.
2. Press grease out of the grease collection container. To do this, push the internal piston back with a rod. The rod may have a maximum diameter of 10 mm. Collect the extracted grease and dispose it properly.
3. Check the collecting vessel. If the collecting vessel is damaged, replace it with a new one.
4. Screw the collecting vessel back into the drain hole on the motor adapter.

5.2.8 Change the oil

On the figures in Section 7.1 "Versions and mounting position" the positions of the oil drain screw, the oil level screw and the vent screw, if present, are shown depending on the mounting position.



WARNING

Danger of burns

The oil may be very hot. Use protective equipment.

Procedure:

1. Place a collection vessel under the oil drain screw or the oil drain tap.
2. Screw out the oil level screw (if present) and the oil drain screw. When using an oil reservoir tank, screw out the screw plug with dipstick.
3. Completely drain the oil from the gear unit.
4. Check the sealing rings of the oil drain screw and the oil level screw. If a sealing ring is damaged, replace the corresponding screw. You can also clean the threads and coat them with securing adhesive e.g. Loctite 242 54-03 before screwing them in.
5. Screw the oil drain screw into the hole and tighten to the correct torque (see chapter 7.3 "Screw tightening torques").
6. Using a suitable filling device, refill with oil of the same type through the oil level hole until oil emerges from the oil level hole. The oil can also be filled through the hole of the pressure vent screw or of a screw plug located higher than the oil level. If an oil reservoir tank is used, fill the oil through the upper inlet (thread G1¼) until the oil level is set as described in Section 5.2.3 "Checking the oil level".
7. Check the oil level after at least 15 min, if using an oil level container after at least 30 min.



Information

The oil does not need to be replaced for gear units without oil drain screws (see chapter 7.1 "Versions and mounting position"). The gear unit are lifelong lubricated.

Standard helical gear units do not have an oil level screw. Here, new oil is injected through the threaded hole of the vent.

5.2.9 Clean and check vent screw

1. Unscrew the vent screw.
2. Thoroughly clean the vent screw, e.g. with compressed air.
3. Check the vent screw and the sealing ring. If the sealing ring is damaged, use a new vent screw.
4. Screw the vent screw back in.

5.2.10 Replacing the shaft sealing ring

Once the shaft sealing ring has reached the end of its service life, the oil film in the region of the sealing lip increases and a measurable leakage with dripping oil occurs. **The radial shaft seal must then be replaced.** The space between the sealing lip and the protective lip must be filled approximately 50 % with grease on fitting (recommended grease: PETAMO GHY 133N). Take care that after fitting, the new radial shaft seal does not run in the old wear track.

5.2.11 Re-lubrication of bearings in the gear unit

NOTICE

Damage to the gear unit due to insufficient lubricant

There is a risk of bearing failure in the event of inadequate lubrication.

- It is essential to comply with the recommended intervals.
- Only use greases which are approved by Getriebebau NORD.
- Never mix different greases. If different greases are mixed, the gear unit may be damaged due to inadequate lubrication caused by incompatibility between the different greases.
- Avoid contamination of the grease with foreign substances and washing out of the grease by lubricating oil.

Please contact the NORD Service department for replacement of the grease in the roller bearings.

Recommended grease: Petamo GHY 133N - Klüber Lubrication. (see chapter 7.2.1 "Roller bearing greases")

5.2.12 General overhaul

The general overhaul must be carried out by a specialist workshop with suitable equipment and be qualified personnel with appropriate equipment in observance of national regulations and laws. We recommend that the general overhaul is carried out by the NORD Service Department.

During general overhaul, the gear unit is completely dismantled. The following work steps are carried out:

- All gear unit components are cleaned.
- All gear unit components are checked for damage.
- Damaged parts are replaced.
- All roller bearings are replaced.
- Replace all seals, radial shaft seals and Nilos rings.
- Optional: The back stop will be renewed.
- Optional: Replace the elastomers in the coupling.

6 Disposal

Observe the current local regulations. In particular, lubricants must be collected and disposed of correctly.

Gear unit components	Material
Gearwheels, shafts, roller bearings, keys, circlips, ...	Steel
Gear unit housing, housing components, ...	Grey cast iron
Light alloy gear unit housing, light alloy housing components, ...	Aluminium
Worm gears, sockets, ...	Bronze
Radial shaft seals, sealing caps, rubber components, ...	Elastomers with steel
Coupling components	Plastic and steel
Flat seals	Asbestos-free sealing material
Gear oil	Additive mineral oil
Synthetic gear oil (adhesive label: CLP PG)	Polyglycol-based lubricants
Synthetic gear oil (adhesive label CLP PG)	Poly-alpha-olefin based lubricants
Cooling coil, embedding material of the cooling coil, screw fittings	Copper, epoxy, yellow brass

Table 11: Materials

7 Appendix

7.1 Versions and mounting position

Information

The gear unit types SK 320, SK 172, SK 272, SK 372 as well as SK 273 and SK 373, the gear unit types SK 01282 NB, SK 0282 NB and SK 1382 NB and the UNIVERSAL/MINIBLOC gear unit types are lifelong lubricated. These gear units do not have oil level screws.

7.1.1 Explanation of symbols



Vent



Oil level



Oil drain

7.1.2 UNIVERSAL/MINIBLOC worm gear units

NORD UNIVERSAL/MINIBLOC worm gear units are suitable for all installation positions. They have an oil filling which is independent of the mounting position.

As an option, types SI and SMI can be equipped with a vent screw. Gear units with vents must be installed in the stated mounting position.

Types SI, SMI, S, SM and SU as 2-stage gear unit types and types SI, SMI as worm gear units for direct motor mounting have an oil filling which depends on the mounting position and must be installed in the stated position.

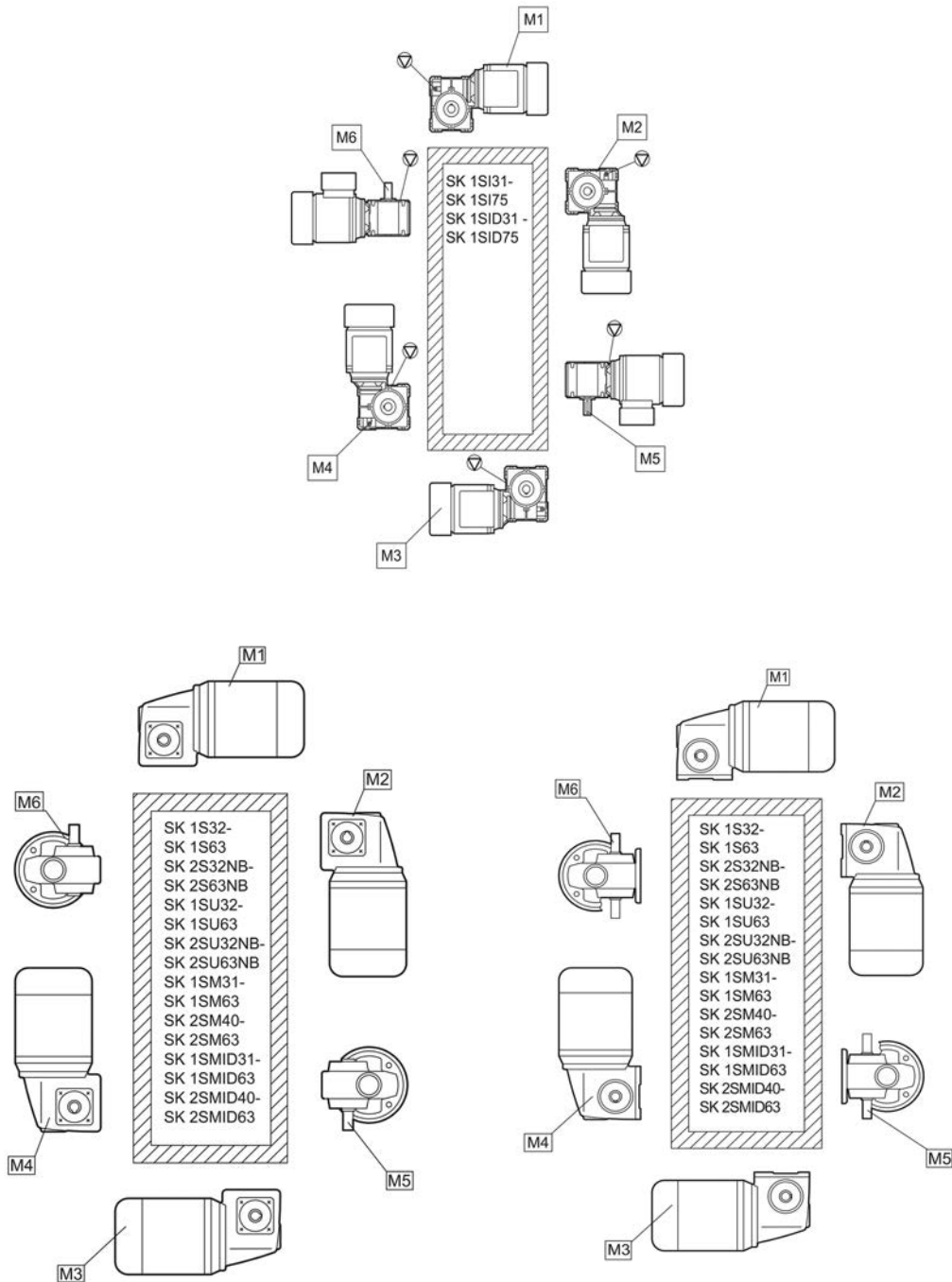

7.1.3 Parallel shaft gear units with oil level tank

The following illustration applies to the M4 configuration of gear unit types SK 9282, SK 9382, SK 10282, SK 10382, SK 10382.1, SK 11282, SK 11382, SK 11382.1 and SK 12382 with oil reservoir tank.

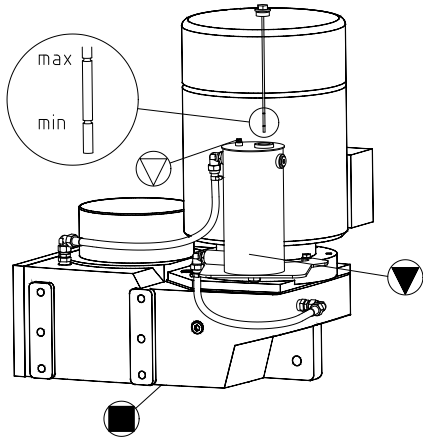
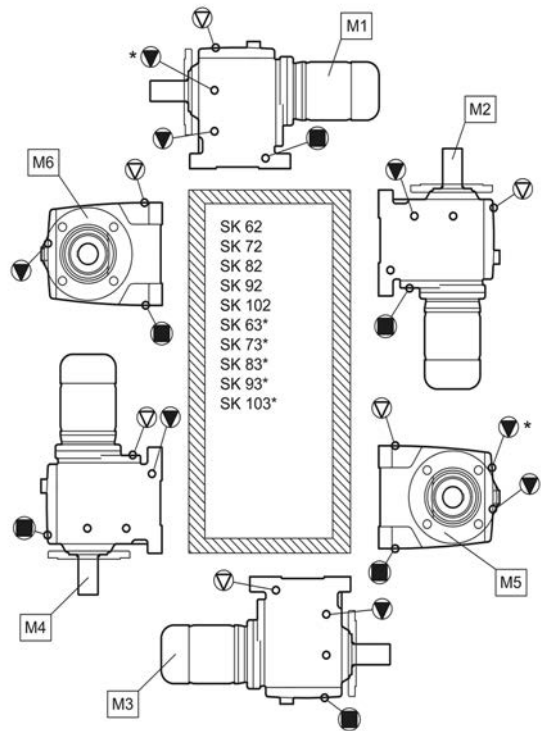
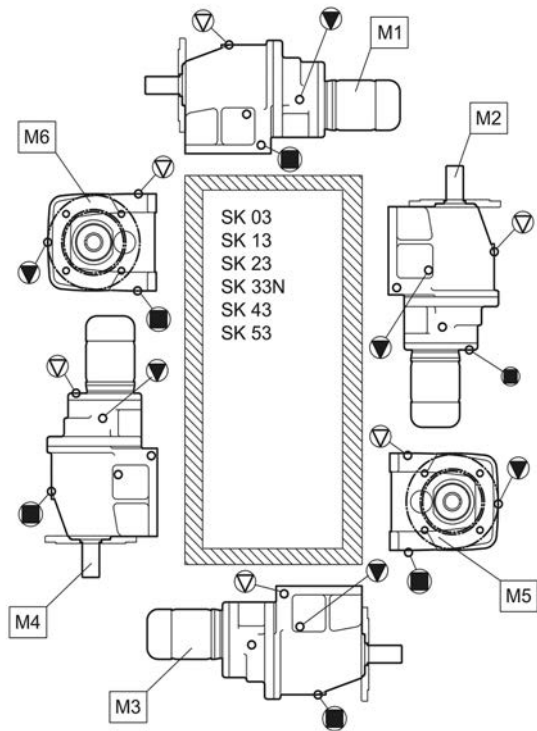
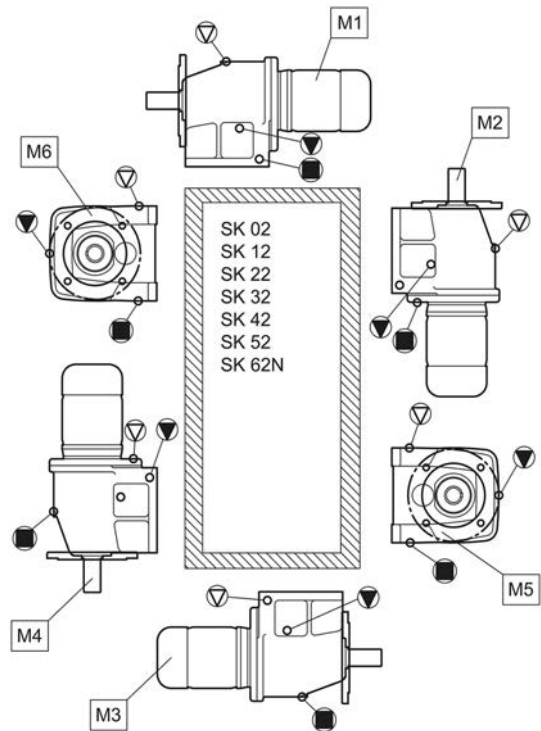
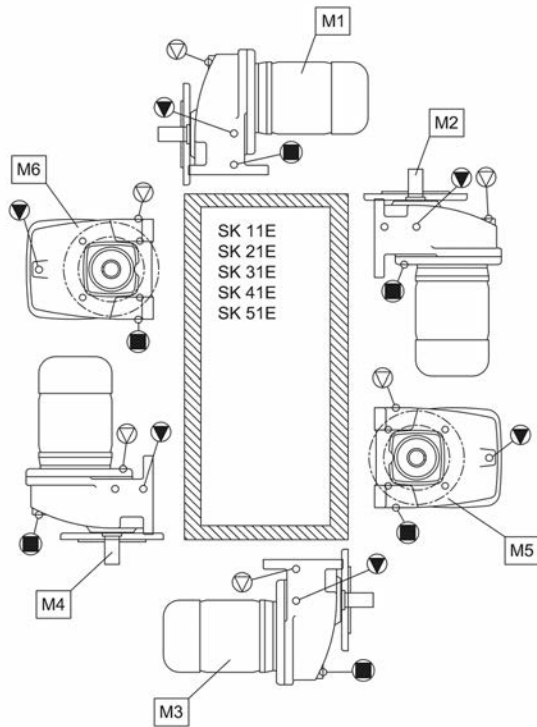
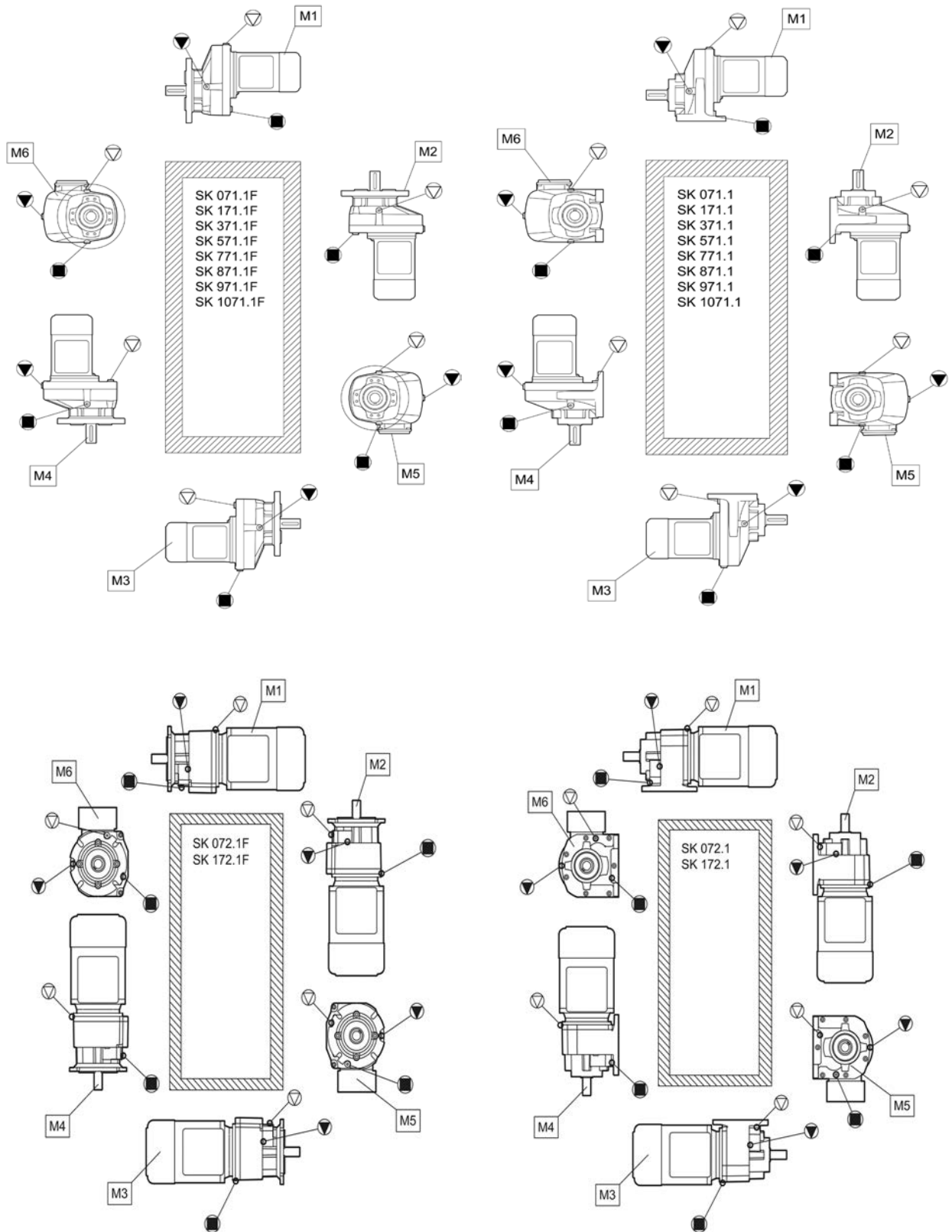
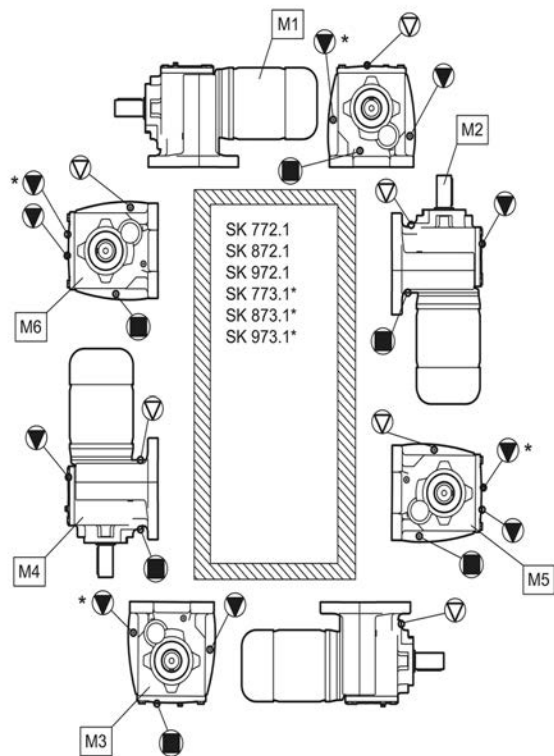
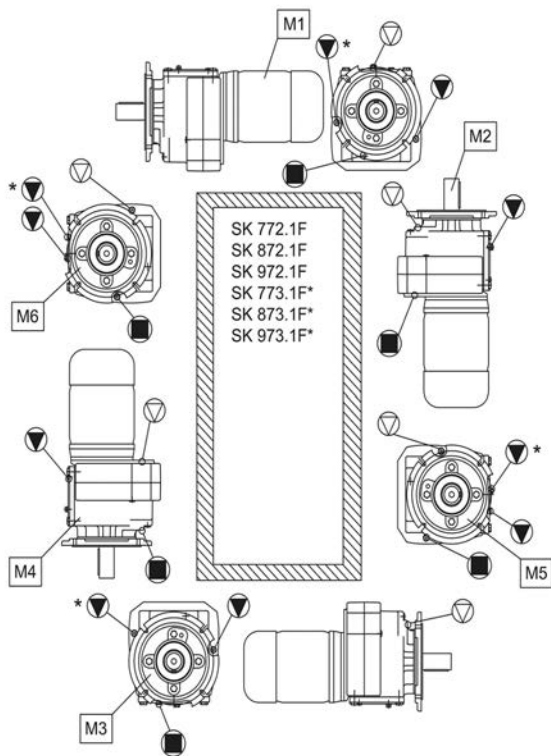
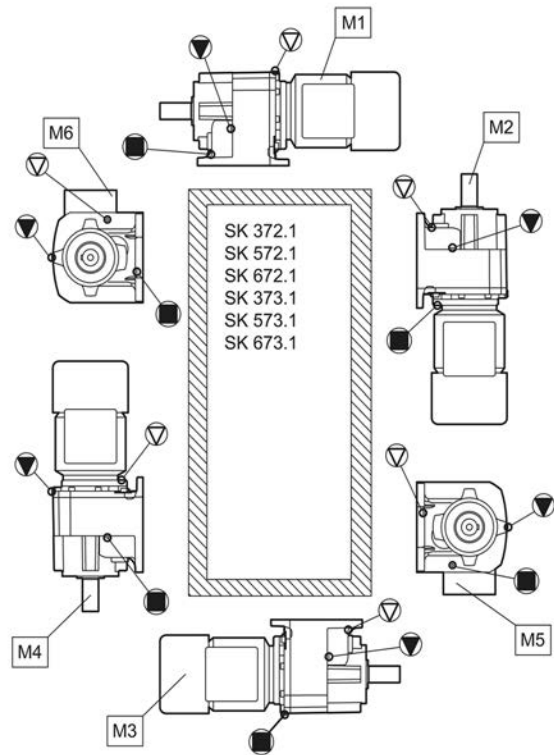
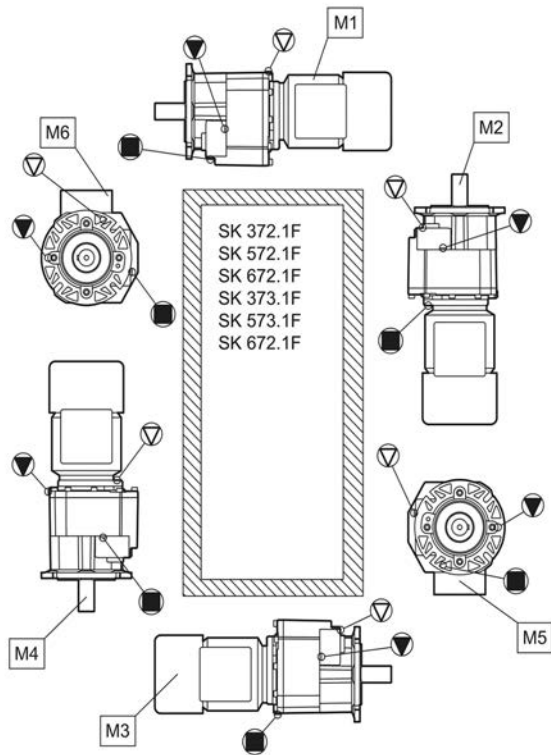

Figure 29: Parallel shaft gear units with oil level tank

7.1.4 Overview of mounting positions







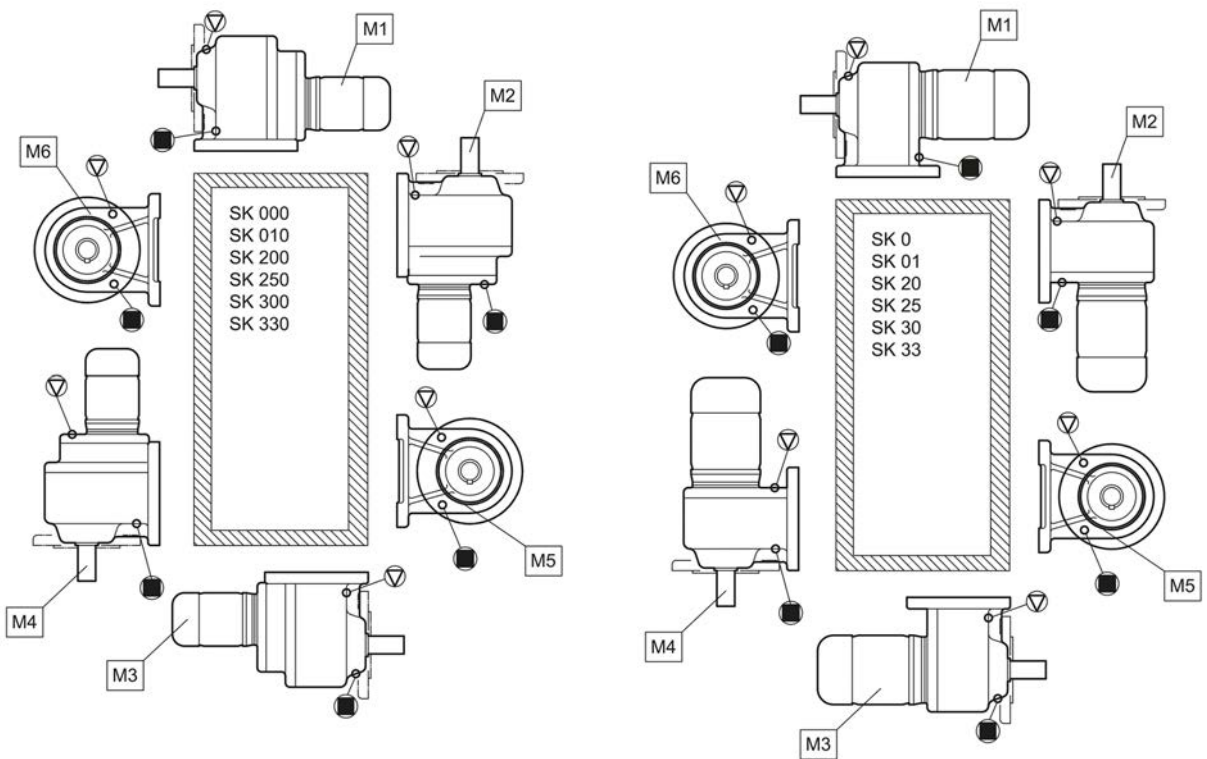
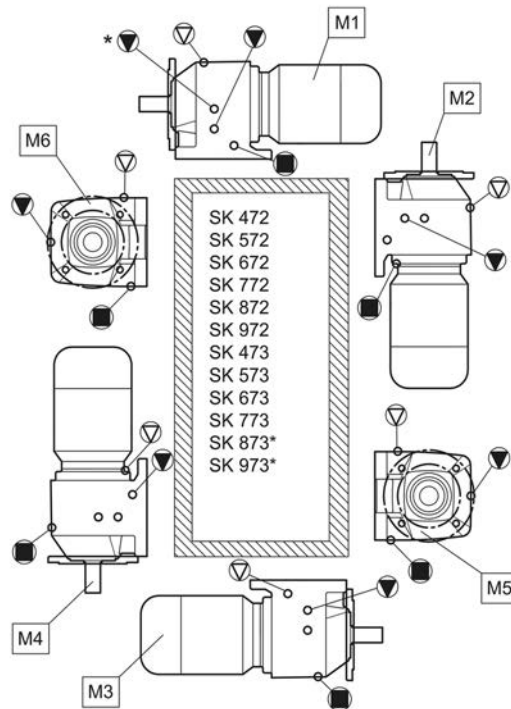

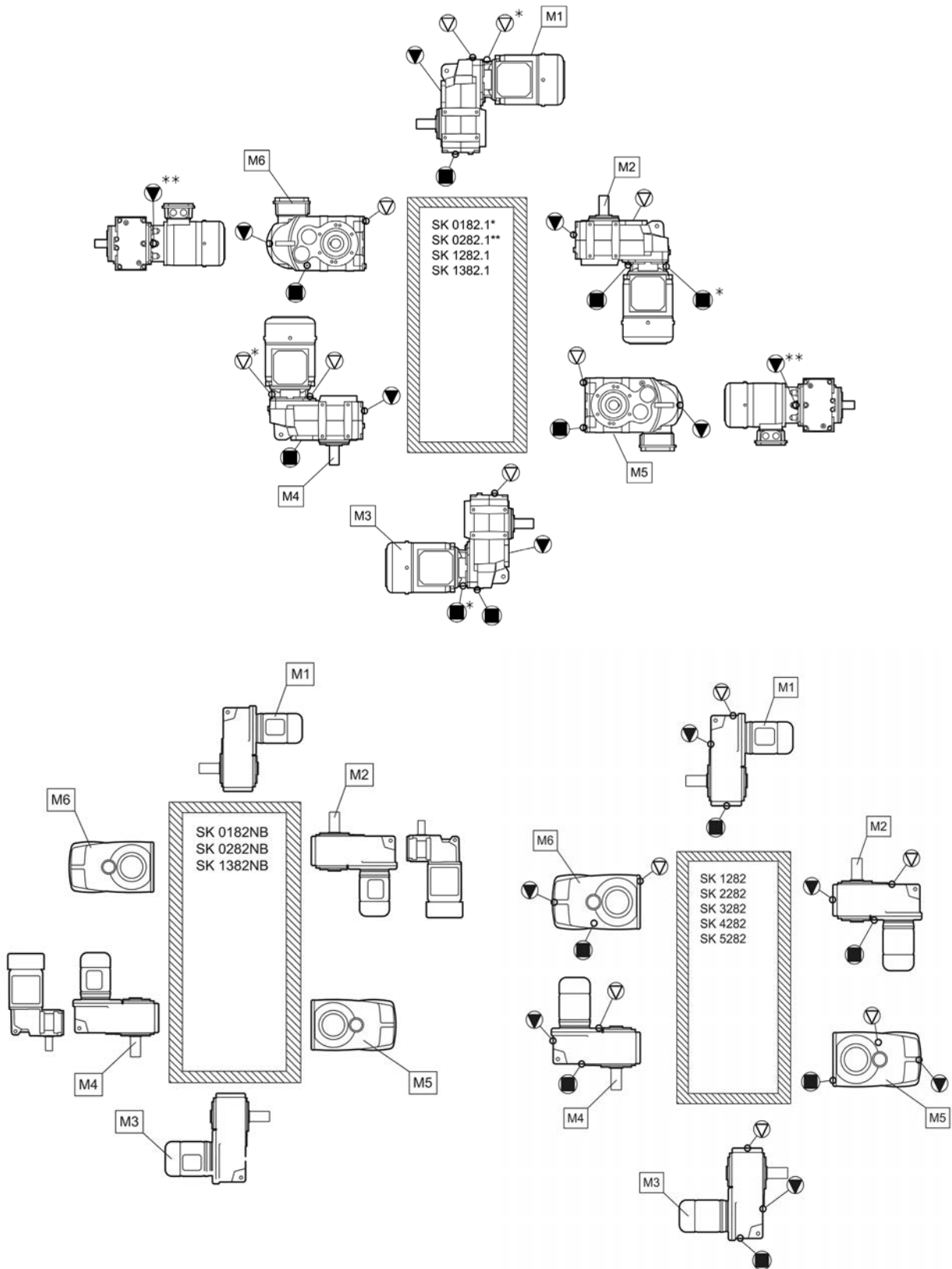

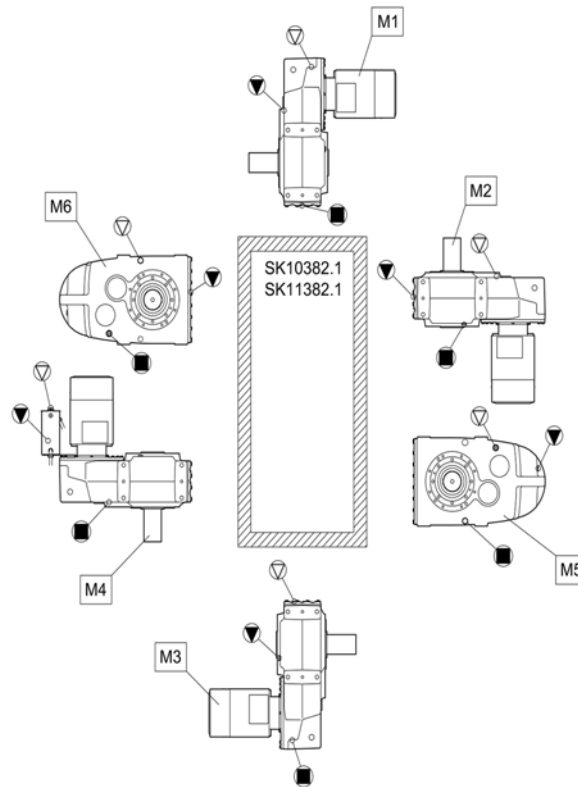
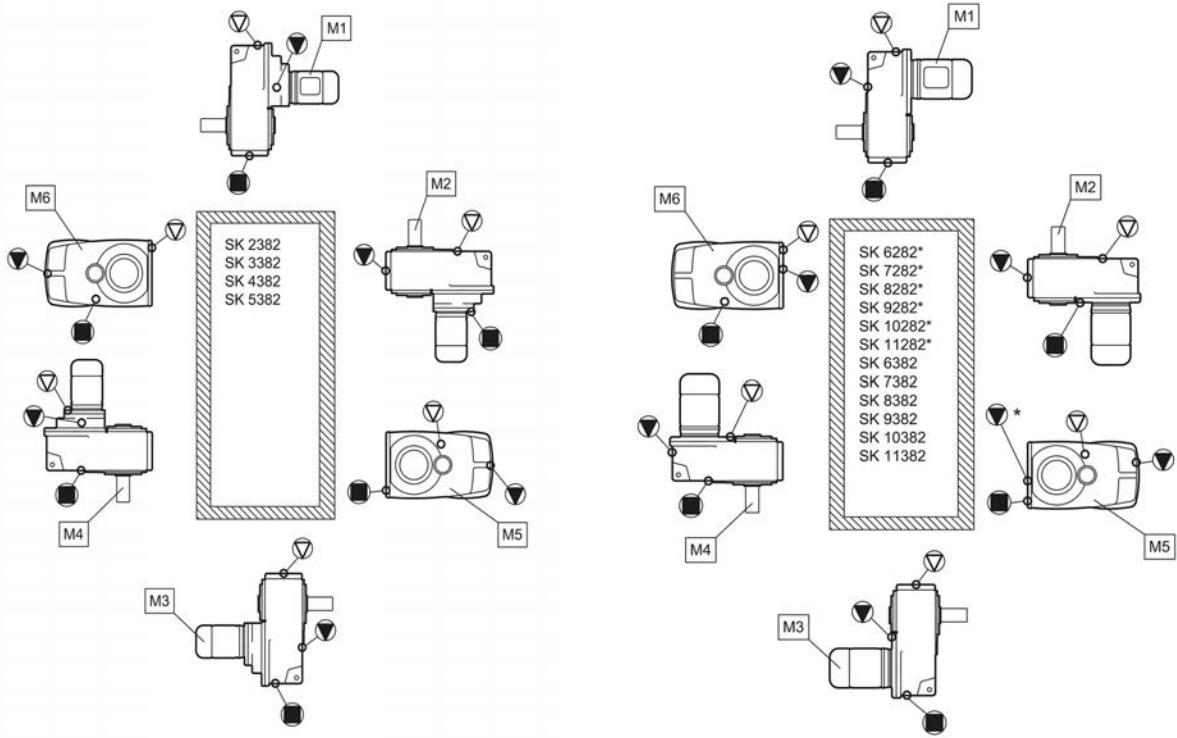

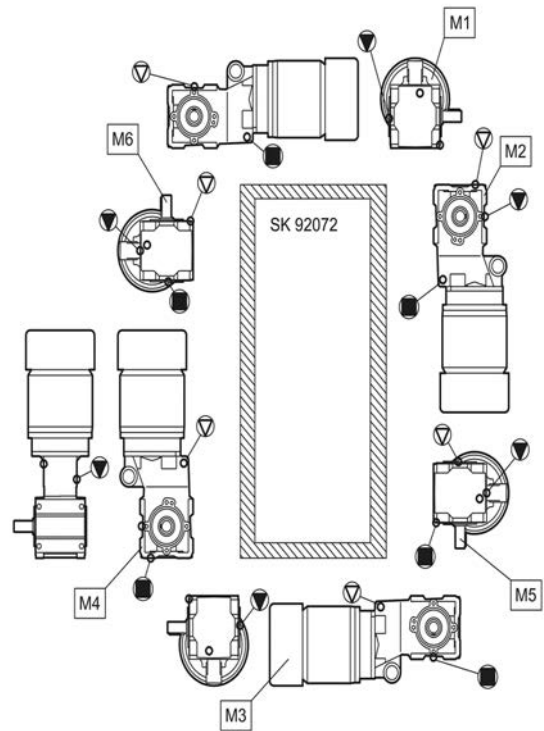
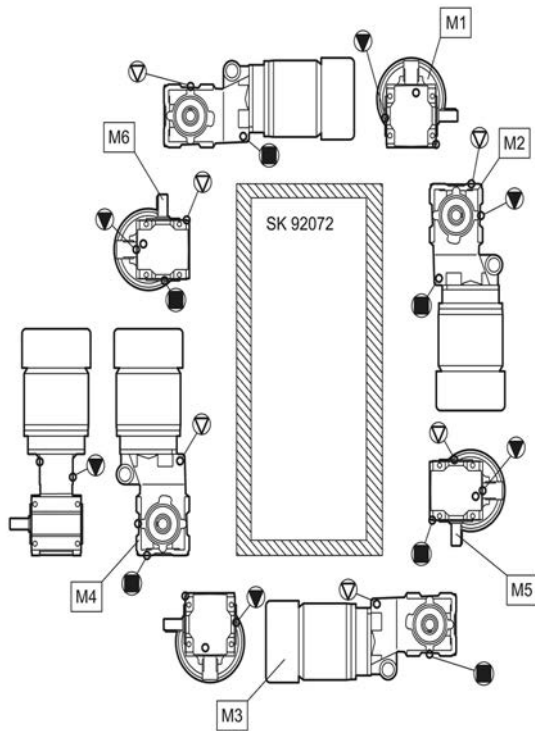
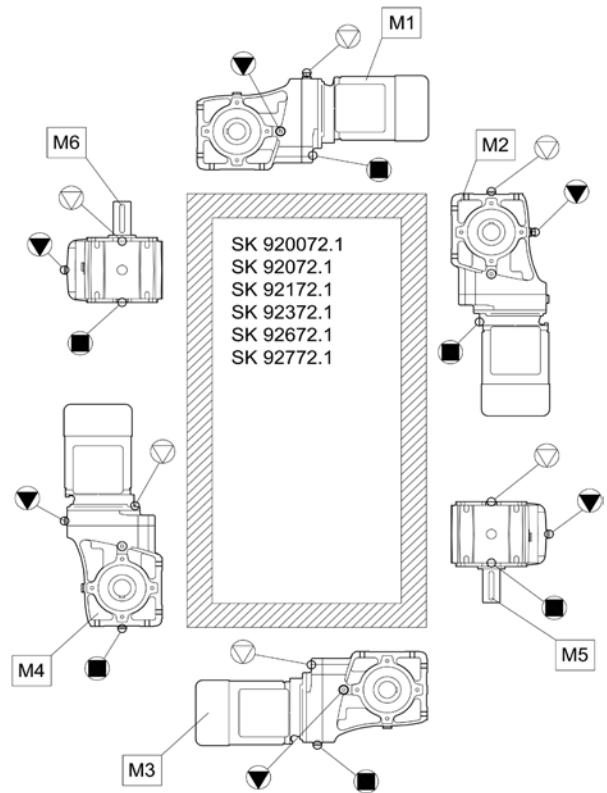
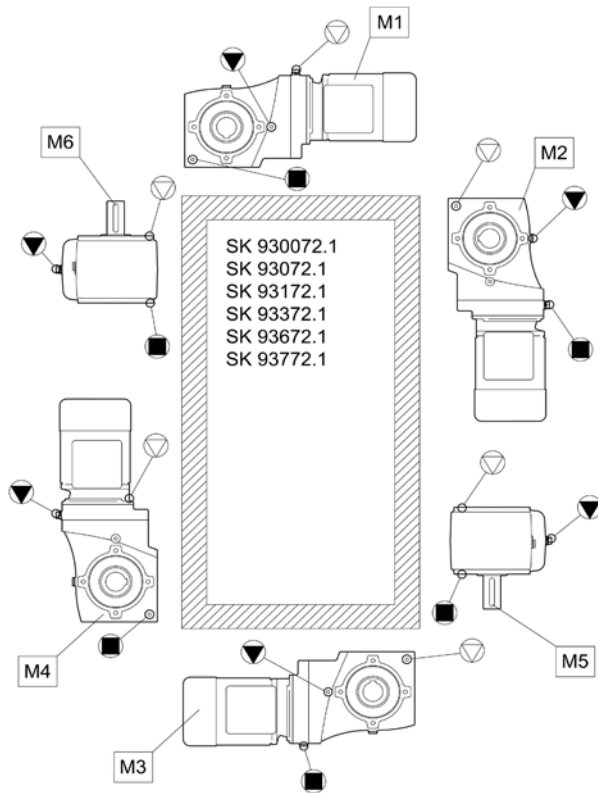

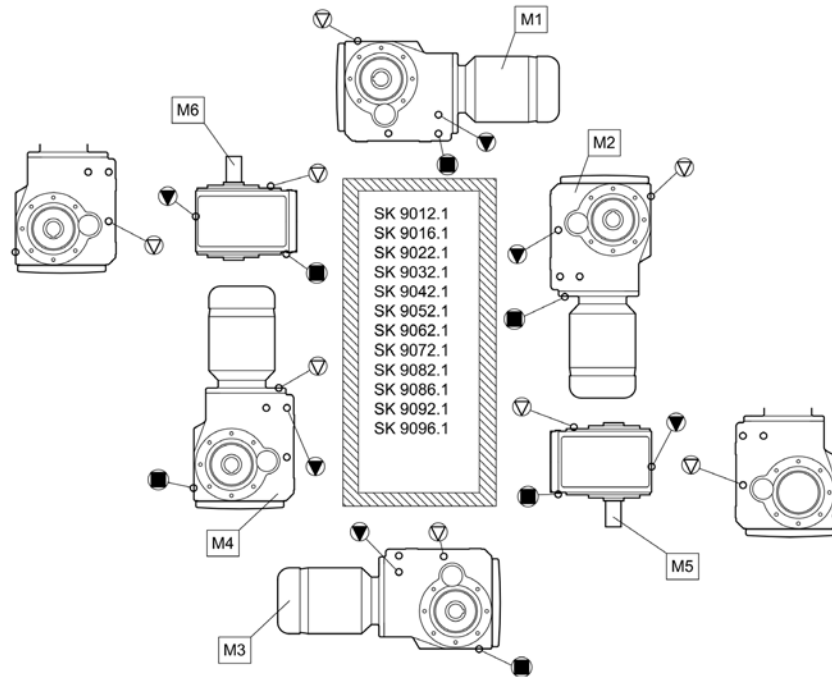
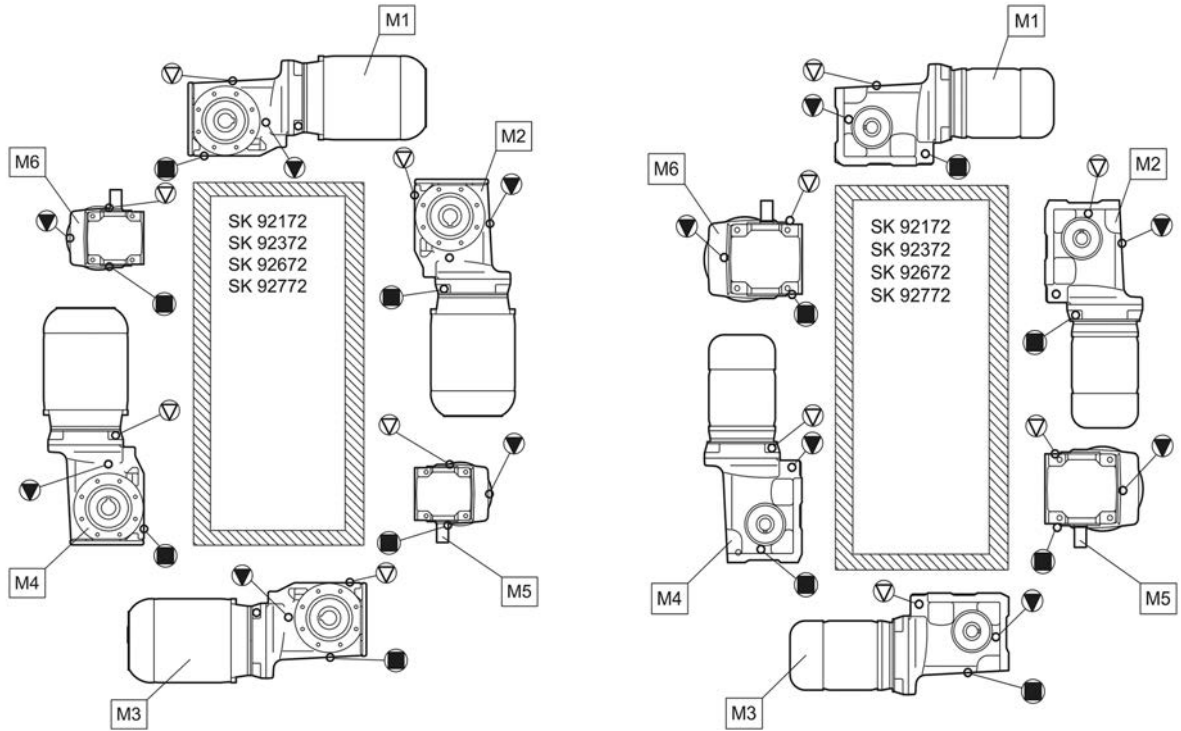

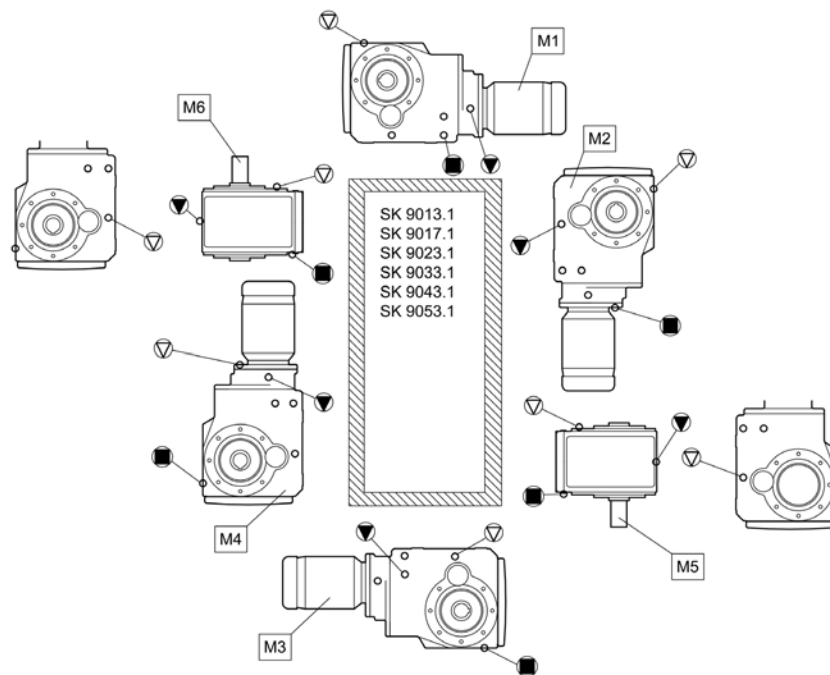
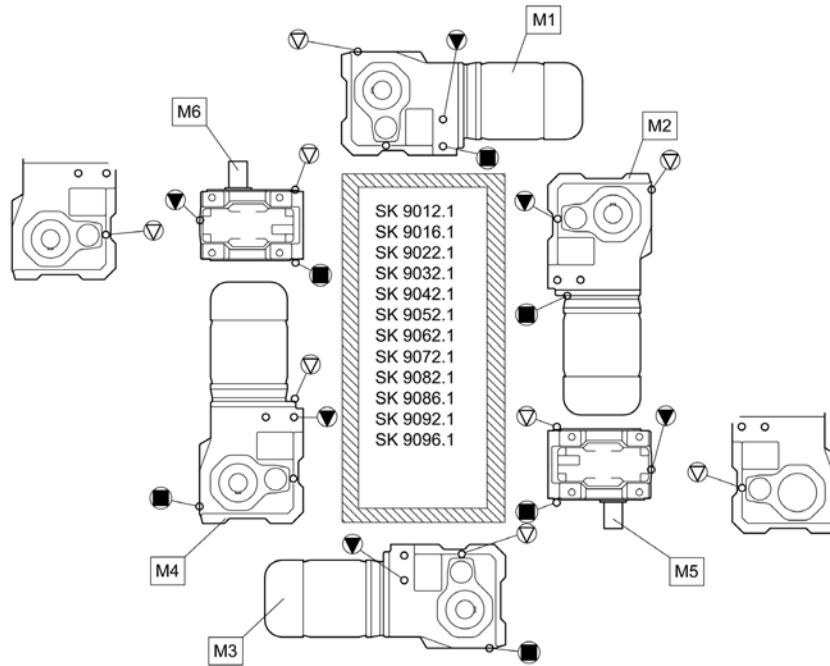

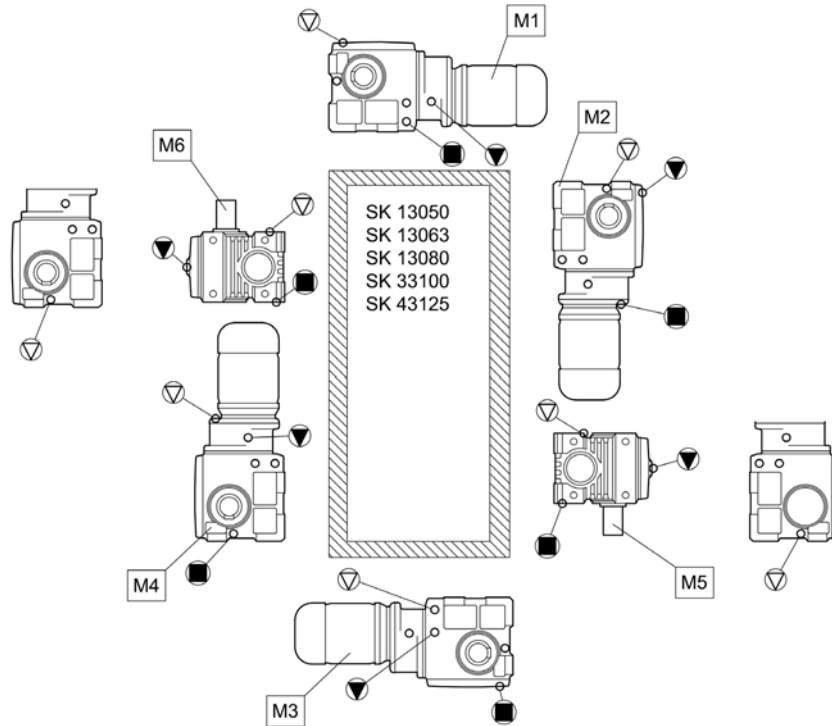
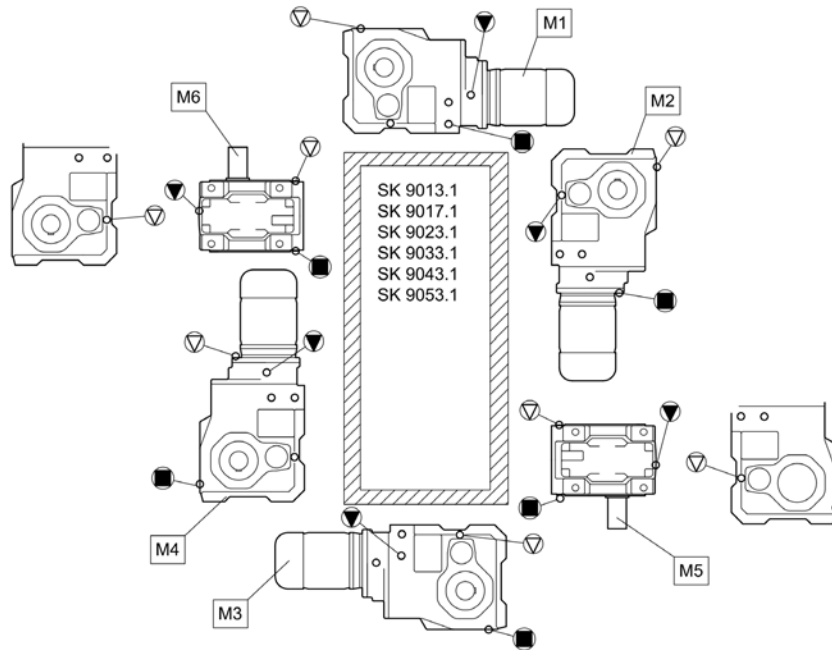

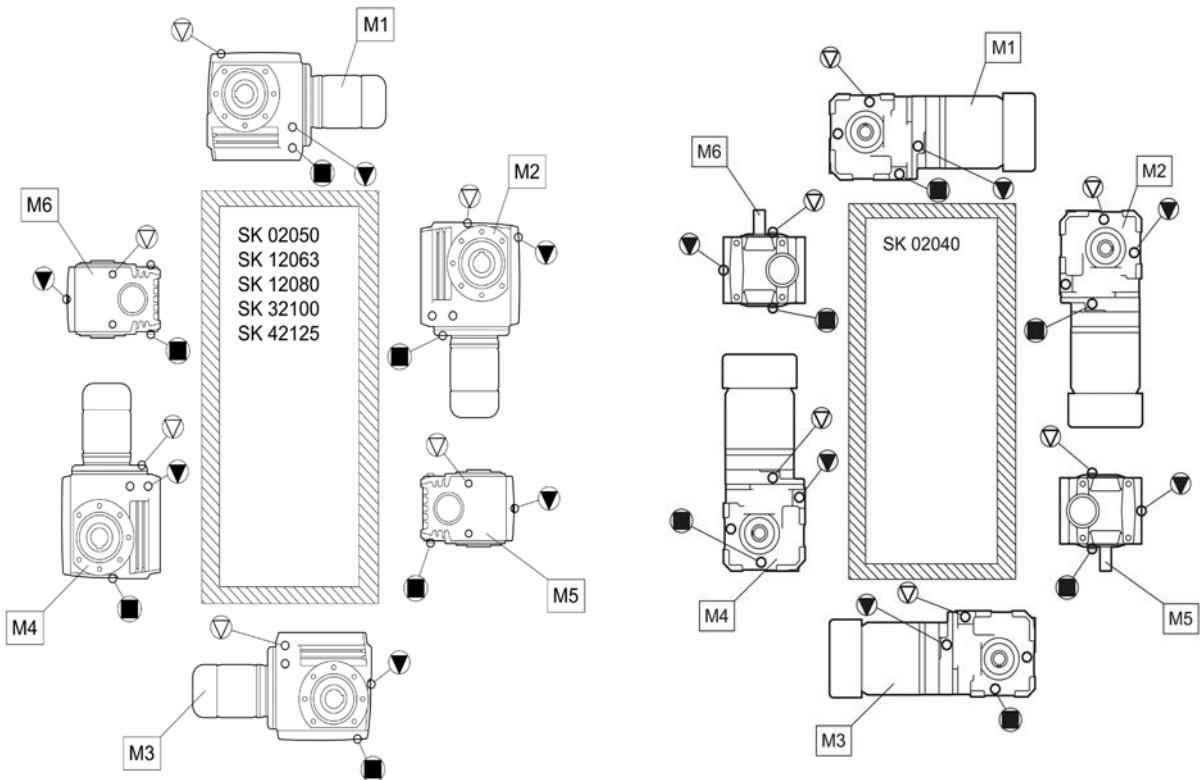
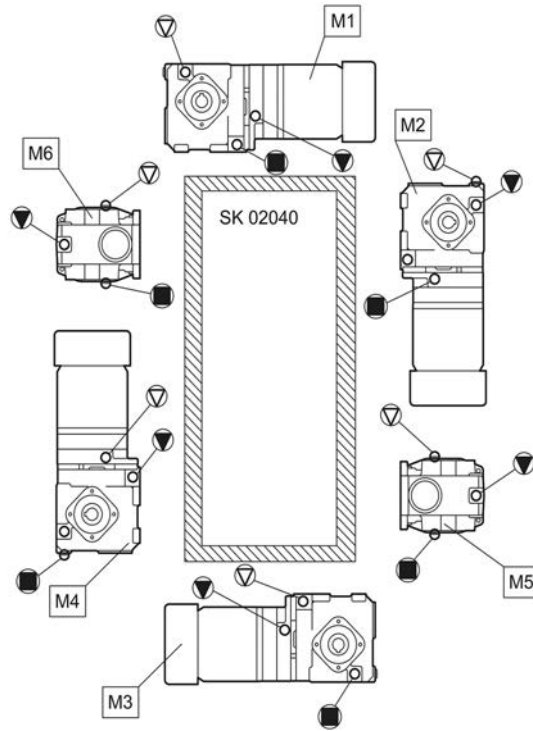

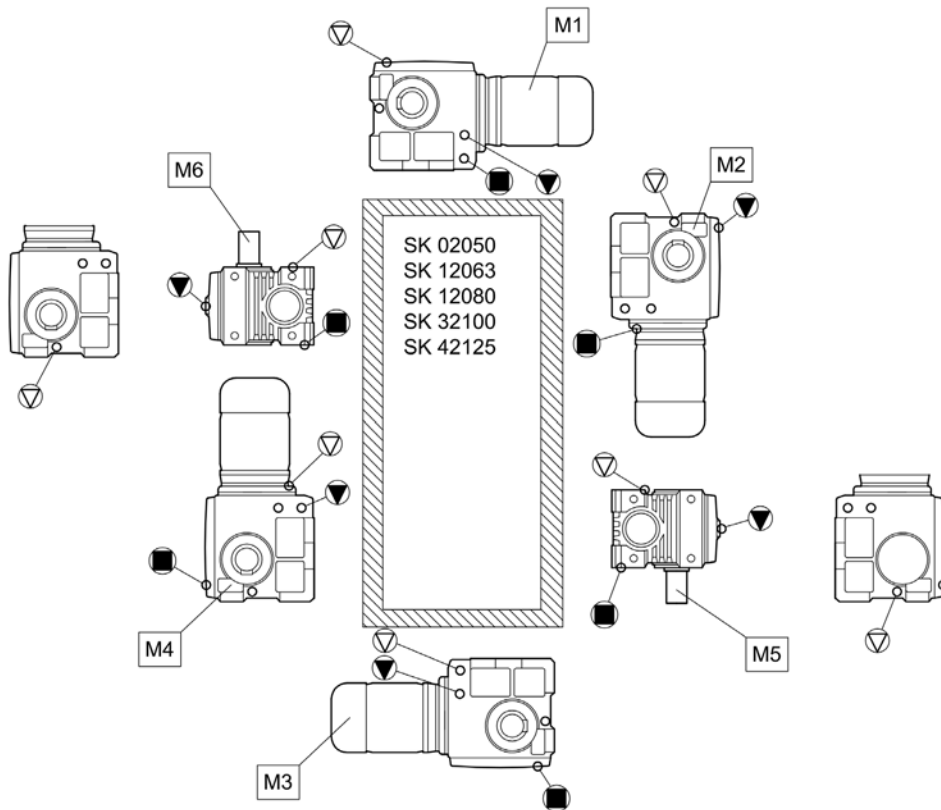
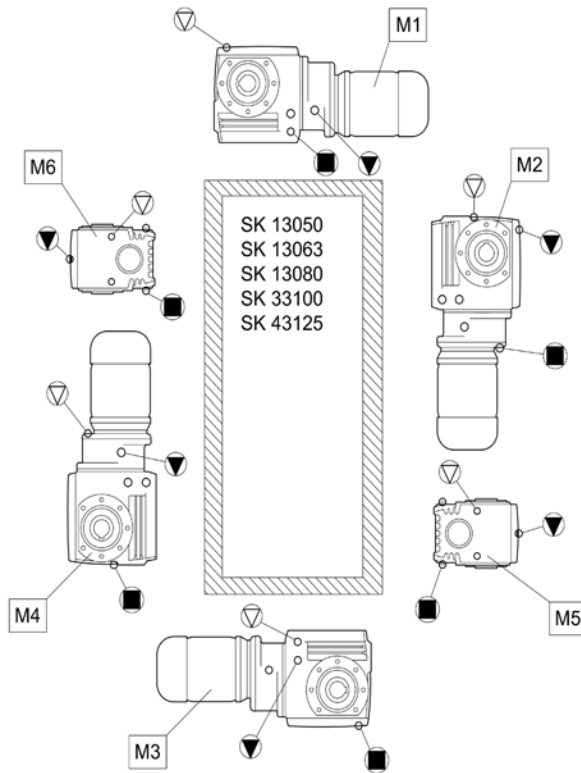

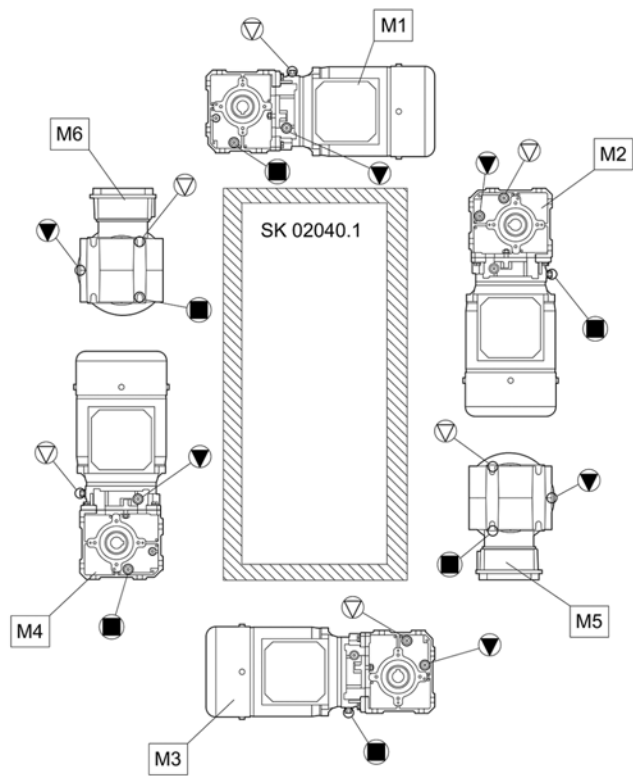

7.2 Lubricants

With the exception of types SK 11382.1, SK 12382 and SK 9096.1, the gear units are filled with lubricant for the required mounting position and are ready for operation as delivered. The initial filling corresponds to a lubricant from the column for the ambient temperatures (standard version) in the lubricant table.

7.2.1 Roller bearing greases

This table contains comparable approved roller bearing greases from various manufacturers. The manufacturer can be changed within a lubricant type. Observe the ambient temperature range.

Mixing different greases is not permissible. When changing the grease, different greases of one lubricant type within the relevant ambient temperature range may be mixed in a maximum ratio of 1/20 (5%).

When changing the lubricant type or the ambient temperature range, please consult Getriebebau NORD. Otherwise, no warranty can be accepted for the function of the gear units.





Lubricant type	Ambient temperature				
Grease (mineral oil)	-30...60 °C	Sphereol EPL 2	-	Mobilux EP 2	Gadus S2 V220 2
Grease (PAO)	-25...80 °C	-	PETAMO GHY 133 N	-	-

Table 12: Roller bearing greases

7.2.2 Gear oils

This table shows comparable approved lubricants from various manufacturers. The oil manufacturer can be changed within a viscosity and lubricant type. Only change the lubricant type or the viscosity after consultation with Getriebebau NORD.

Mixing different oils is not permissible. When changing the gear oil, different oils of one lubricant type with the same viscosity may be mixed in a maximum ratio of 1/20 (5%).





Lubricant type	Details on name plate	DIN (ISO) / Ambient temperature					
Mineral oil	CLP 680	ISO VG 680 0...40 °C	-	-	-	Mobilgear 600 XP 680	Omala S2 GX 680
	CLP 220	ISO VG 220 -10...40 °C	Alpha EP 220 Alpha SP 220	Renolin CLP 220 Renolin CLP 220 VCI	Klüberoil GEM 1-220 N	Mobilgear 600 XP 220	-
	CLP 100	ISO VG 100 -15...25 °C	-	-	Klüberoil GEM 1-100 N	-	-
Synthetic oil (Polyglycol)	CLP PG 680	ISO VG 680 -20...40 °C	-	-	Klübersynth GH 6-680	-	-
	CLP PG 460	ISO VG 460 -25...80 °C	-	-	Klübersynth GH 6-460	-	-
	CLP PG 220	ISO VG 220 -25...80 °C	Optigear Synthetic 1300/220	Renolin PG 220	Klübersynth GH 6-220	-	-
Synthetic oil (hydrocarbon)	CLP HC 680	ISO VG 680 -30...80 °C	-	-	Klübersynth GEM 4-680	Mobil SHC 636	-
	CLP HC 460	ISO VG 460 -30...80 °C	-	-	-	Mobil SHC 634	-
	CLP HC 220	ISO VG 220 -40...80 °C	Alphasyn EP 220	Renolin UNISYSN XT 220 Renolin Unisyn CLP 220 Renolin Unisyn Gear 220 VCI	Klübersynth GEM 4-220 N Klübersynth MEG 4-220	Mobil SHC 630 Mobil SHC Gear 630	Omala S4 GX 220
Bio- degradable oil	CLP E 680	ISO VG 680 -5...40 °C	-	Plantogear 680 S	-	-	-
	CLP E 220	ISO VG 220 -5...40 °C	-	Plantogear 220 S	-	-	-
Food grade oil	CLP PG H1 680	ISO VG 680 -5...40 °C	-	-	Klübersynth UH1 6-680	-	-
	CLP PG H1 220	ISO VG 220 -25...40 °C	-	Cassida Fluid WG 220	Klübersynth UH1 6-220	-	-
	CLP HC H1 220	ISO VG 220 -25...40 °C	-	-	-	Mobil SHC Cibus 220	-
Gear unit – fluid grease based on mineral oil	GP 00 K-10	-10 ... 60 °C	Spheerol EPL 00	-	-	-	-
	GP 00 K-30	-30 ... 60 °C	Tribol GR 100-00 PD	-	-	-	-

Table 13: Gear oils

The required lubricant quantity and the lubricant type are stated on the name plate. The precise quantities vary depending on the exact gear ratio and options OSG and OT, if available. When filling,

always observe the oil level screw hole or, with option OT, the dipstick as an indicator of the precise quantity of oil.

After changing the lubricant, and in particular after the initial filling, the oil level may change during the first few hours of operation, as the oil galleries and the hollow spaces only fill gradually during operation. After a short run-in period, we recommend another check of the oil level.

If the gear unit contains an oil inspection glass, we recommend an adjustment of the oil level after an operating time of approximately 2 hours, so that the oil level is visible in the oil inspection glass when the gear unit is at a standstill and has cooled down. An oil level check via the oil inspection glass is only possible after this time.

Gear unit types SK 11282, SK 11382, SK 11382.1, SK 12382 and SK 9096.1 are usually supplied without oil.

7.3 Screw tightening torques

Screw tightening torques [Nm]							
Dimensions	Screw fastenings in strength classes				Cap screws	Threaded pin on coupling	Screw fastenings on covers
	8.8	10.9	12.9	V2A-70 V4A-70			
M4	3.2	5	6	2.8	-	-	-
M5	6.4	9	11	5.8	-	2	-
M6	11	16	19	10	-	-	6.4
M8	27	39	46	24	11	10	11
M10	53	78	91	48	11	17	27
M12	92	135	155	83	27	40	53
M16	230	335	390	207	35	-	92
M20	460	660	770	414	-	-	230
M24	790	1150	1300	711	80	-	460
M30	1600	2250	2650	1400	170	-	-
M36	2780	3910	4710	2500	-	-	1600
M42	4470	6290	7540	4025	-	-	-
M48	6140	8640	16610	5525	-	-	-
M56	9840	13850	24130	8860	-	-	-
G½	-	-	-	-	75	-	-
G¾	-	-	-	-	110	-	-
G1	-	-	-	-	190	-	-
G1¼	-	-	-	-	240	-	-
G1½	-	-	-	-	300	-	-

Table 14: Screw tightening torques

Installing hose unions

Oil the thread of the union nut, the cutting ring and the thread of the connecting piece. Tighten the union nut with a spanner until the union nut becomes more difficult to turn. Turn the union nut further by approx. 30° to 60° but only to a maximum of 90° while holding the connecting piece with a spanner. Remove excess oil from the union.

7.4 Troubleshooting

NOTICE!

Gear unit damage

- Shut down the gear unit immediately in case of malfunction.

Gear unit malfunctions		
Error	Possible cause	Remedy
Unusual running noises, vibrations	Oil too low or bearing damage or gear wheel damage	Consult NORD Service department
Oil escaping from gear unit or motor	Defective seal	Consult NORD Service department
Oil escaping from pressure vent	Incorrect oil level	Use oil expansion chamber (Option OA)
	Incorrect, dirty oil	Oil change
	Unfavourable operating conditions	Consult NORD Service department
Gear unit becomes too hot	Unfavourable installation conditions or gear unit damage	Consult NORD Service department
Shock when switching on, vibrations	Motor coupling defective	Replace elastomer ring
	Gear unit fastening loose	Tighten motor and gear unit fastening screws
	Defective rubber element	Replace rubber element
Output shaft does not rotate although motor is running	Breakage in gear unit	Consult NORD Service department
	Motor coupling defective	
	Shrink disc slip	

Table 15: Overview of malfunctions

7.5 Leakage and leak-tightness

Gear units are filled with oil or grease to lubricate the moving parts. Seals prevent the escape of lubricants. Full leak-tightness is technically not possible, as a certain film of moisture, for example on the radial shaft seals is normal and advantageous for a long-term sealing effect. In the region of vents, oil moisture may be visible due to the escape of function-related oil mist. In the case of grease-lubricated labyrinth seals such as Taconite sealing systems, the used grease emerges from the sealing gap. This apparent leak is not a fault.

According to the test conditions as per DIN 3761, the leak is determined by the medium to be sealed. In bench tests, it exceeds the function-related moisture on the sealing edge in a defined test period and results in dripping of the medium to be sealed. The measured quantity which is then collected is designated as leakage.

Definition of leakage according to DIN 3761 and its appropriate use					
Term	Explanation	Location of leakage			
		Radial shaft seal	In IEC adapter	Housing joint	Vent
Sealed	No moisture apparent	No fault present			
Damp	Moisture film locally restricted (not an area)	No fault present			
Wet	Moisture film beyond the extent of the component	No fault present		Check, if repair is necessary	No fault present
Measurable leakage	Recognisable stream, dripping	Repair recommended			
Temporary leakage	Temporary malfunction of the sealing system or oil leak due to transport *)	No fault present		Check, if repair is necessary	No fault present
Apparent leakage	Apparent leakage, e.g. due to soiling or sealing systems, which can be re-lubricated	No fault present			

Table 16: Definition of leakage according to DIN 3761

*) Previous experience has shown that moist or wet radial shaft seals stop leaking in the further process. Therefore, under no circumstances can replacement be recommended at this stage. The reason for momentary moisture may be e.g. small particles under the sealing lip.

7.6 Repair information

For enquiries to our technical and mechanical service department, please have the exact gear unit type and, if applicable, the order number to hand. You can find this information on the name plate.

7.6.1 Repairs

In case of repair, remove all non-original parts from the gear unit or geared motor. No guarantee can be given for any attached parts, such as rotary encoders or external fans.

Send the device to the following address:

Getriebebau NORD GmbH & Co. KG
Serviceabteilung
Getriebebau-Nord-Straße 1
22941 Bargteheide

Information

If possible, state the reason for returning the component/device. Specify a contact person for queries. This is important in order to keep repair times as short as possible.

7.6.2 Internet information

In addition, you will find the manuals in the available languages on our website: www.nord.com.

7.7 Warranty

NORD GmbH & Co. KG accepts no liability for damage to persons, materials or assets as a result of failure to observe this operating manual, operating errors or incorrect use. General wearing parts, e.g. radial seals are excluded from the warranty.

7.8 Abbreviations

2D	Dust explosion-proof gear units, Zone 21	F_R	Radial force
2G	Gas explosion-proof gear units, Zone 1	F_A	Axial force
3D	Dust explosion-proof gear units, Zone 22	H1	Lubricant for the food industry
ATEX	AT mosphères EX plosible	IE1	Standard efficiency motors
B5	Flange fastening with through holes	IE2	High efficiency motors
B14	Flange fastening with threaded holes	IEC	International Electrotechnical Commission
CLP	Mineral oil	NEMA	National Electrical Manufacturers Association
CLP HC	Synthetic polyalphaolefin oil	IP55	International protection
CLP PG	Synthetic polyglycol oil	ISO	International standardisation organisation
cSt	Centistokes	pH	pH value
CW	Clockwise, right rotation	PPE	Personal Protective Equipment
CCW	Counter-clockwise, left rotation	DIR	Directive
°dH	Water hardness in German hardness degrees 1 dH = 0.1783 mmol/l	UKCA	UK Conformity Assessed
DIN	Deutsches Institut für Normung [<i>German Institute for Standardisation</i>]	VCI	Volatile Corrosion Inhibitor
E	Ester oil	VG	Viscosity group
EC	European Community	WN	Document from Getriebbau NORD
EN	European standard		

Key word index

A

Activating the vent	40
Address	75

C

Change the oil	50
Check the hose	49
Checking the oil level	48
Cooling coil	43
Cooling system	36
Covers	30

D

Disposal of materials	52
-----------------------------	----

E

Electric motor	39
Electrical connection	39

F

Fault	73
-------------	----

G

Gear unit types	13
General overhaul	51
GRIPMAXX™	28

H

H66 option	23
Hollow shaft with GRIPMAXX™ (Option M)	28
Hose union	72

I

Installation	18
Intended use	10
Internet	75
Introduction of forces	21

L

Leakage	74
Long-term storage	17
Lubricant dispenser	41, 50
Lubricant quantities	69

Lubricants	69
------------------	----

M

Maintenance	75
Maintenance intervals	46
Maintenance work	
Check for running noises	47
Checking the oil level	48
Leaks	47
Lubricant dispenser	49
Oil change	50
Radial shaft seal	51
Re-greasing VL2, VL3, W and AI/AN	49
Vent screw	51
Visual inspection	47
Motor	39

N

Name plate	15
nsd tupH	18

O

Oil level	40
Option M	28
Options	14

P

Pulling device	21
Push-on gear unit	23

R

Radial shaft seal	51
Re-grease the bearings	51
Re-greasing	49
Repairs	75
Roller bearing greases	69
Running noises	47
Running-in time	44

S

Safety information	10
Service	75

Gear units – Manual with installation instructions

Service intervals	46	Transport.....	11, 16
Shrink disc	26, 28	V	
Standard motor	33	Vent.....	40
Surface treatment		Vent screw	51
nsd tupH.....	18	Visual inspection	47
T		Visual inspection of hose	49
Tightening torques.....	72		

Headquarters
Getriebebau NORD GmbH & Co. KG
Getriebebau-Nord-Str. 1
22941 Bargteheide, Deutschland
T: +49 45 32 / 289 0
F: +49 45 32 / 289 22 53
info@nord.com