

# WL range

## Mobile Hopper Progressing Cavity Pumps

Specially designed for the wine production, the WL range is provided with trolley and control panel.

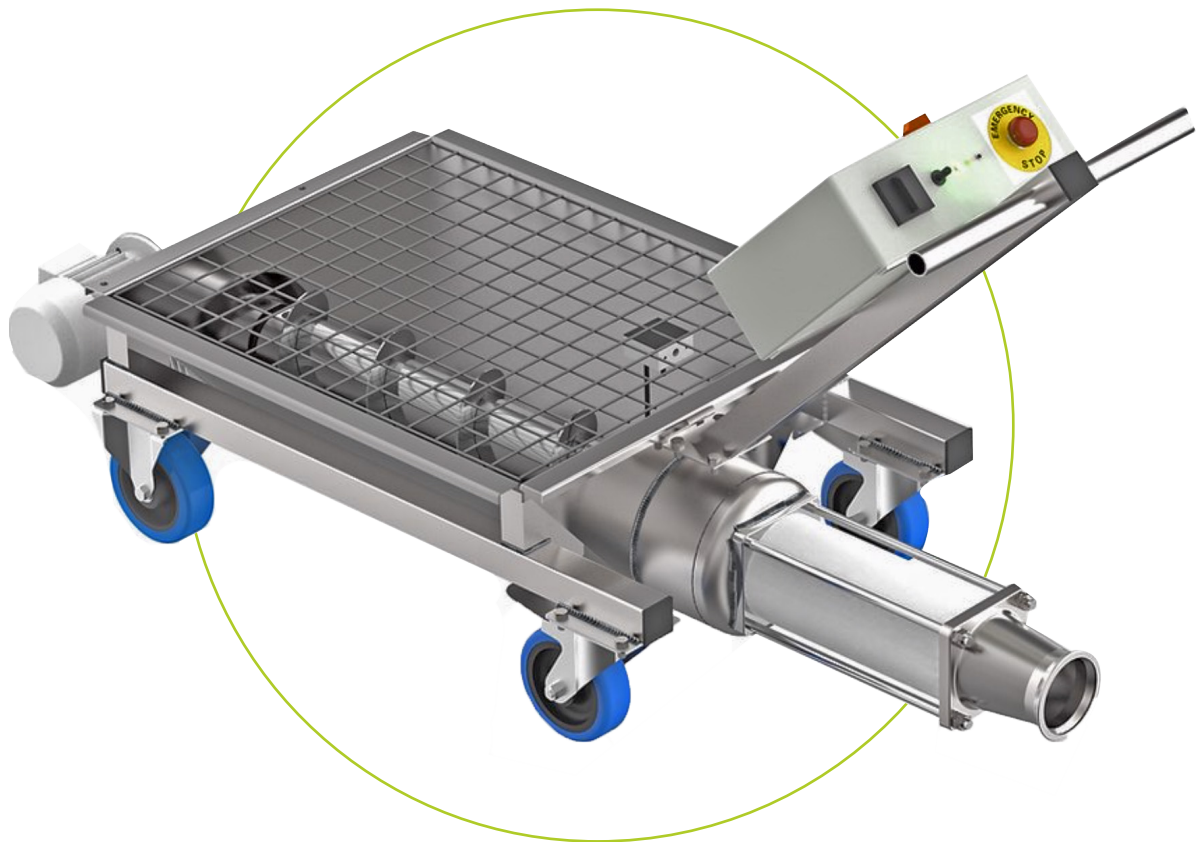

## Advantages

- Robust design, clearest delivery time and best value for money in the market.
- Widest pump's range.
- Open joint to allow easy cleaning
- CE electrical control panel with sophisticated options to provide start-stop and pump protection
- Stainless steel auger, pitched matched to pump speed ensuring pump charge is maintained
- Hopper design enabling easy cleaning



The compact and robust design of the WL mobile hopper progressing cavity pump makes it ideal for transferring whole or destemmed grapes and it can be installed right under the destemmer. It can also be used during the decanting process.

This PCP model is perfectly suited for food and beverages liquids pumping such as grapes, juice, olive oil, parts of vegetables, and pastes of olive or tomato, jams, preserves and marmalades.

Resilient high torque reduction gearbox with precision Helical Bevel gears

Stainless steel 304 construction hopper

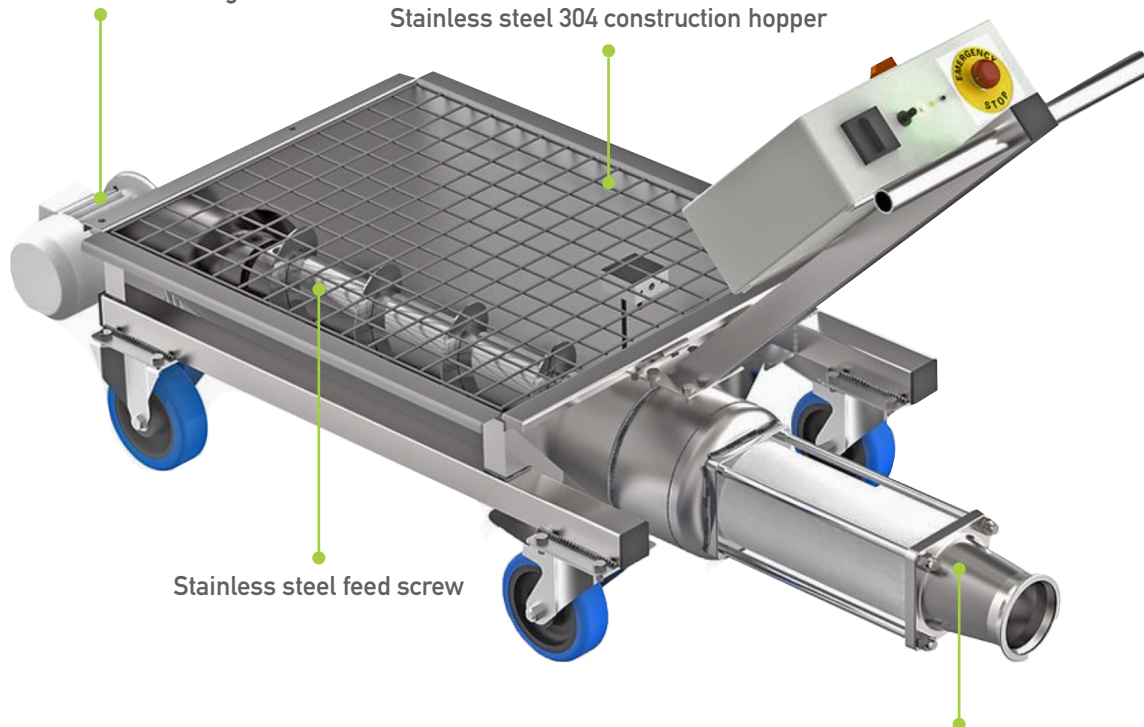

Stainless steel feed screw

Wine coupling, Triclamp or Din 11851 outlet flange

#### APPLICATION FIELDS

Industrial applications in environmental technology

Industrial applications in in the food industry.

Industrial applications in in the oil & gas industry

Industrial applications in the chemical industries

Industrial applications for fluid to viscous media with and without solids.